



ELECTRIC VEHICLE SOLUTIONS GUIDE

Battery, Motor and Inverter, and General Assembly Solutions

COGNEX

THE GLOBAL LEADER

IN MACHINE VISION AND INDUSTRIAL BARCODE READING

Cognex®, the leading supplier of machine vision and industrial barcode reading solutions.

With over 3 million systems installed in facilities around the world and over forty years of experience, Cognex is focused on industrial machine vision and image-based barcode reading technology. Deployed by the world's top manufacturers, suppliers and machine builders, Cognex products ensure that manufactured items meet the stringent quality requirements of each industry.

Cognex solutions help customers improve manufacturing quality and performance by eliminating defects, verifying assembly and tracking information at every stage of the production process. Smarter automation using Cognex vision and barcode reading systems means fewer production errors, which equates to lower manufacturing costs and higher customer satisfaction. With the widest range of solutions and largest network of global vision experts, Cognex is the best choice to help you **Build Your Vision.™**

**\$811
MILLION**
2020 REVENUE

OVER 40
YEARS IN THE BUSINESS

500+
CHANNEL PARTNERS

GLOBAL OFFICES IN
20+ COUNTRIES

3,000,000+
SYSTEMS SHIPPED



THE RIGHT CHOICE FOR ELECTRIC VEHICLE MANUFACTURING

MACHINE VISION AND BARCODE READING SOLUTIONS THAT GO THE DISTANCE

Machine vision is used throughout electric vehicle (EV) production to inspect materials for quality and consistency and to guide, align, and identify components. EV manufacturers and hardware suppliers are uniformly focused on achieving greater energy density, cycle life, and safety. During production, stable manufacturing processes are essential to prevent degradation and minimize waste. Cognex machine vision and image-based barcode reading technologies help manufacturers and suppliers adhere to the most rigorous quality standards and ensure high performance for their batteries, motors, inverters, and general assemblies.

Battery	4	General Assembly	11
Electrode	4	Tire and Wheel Systems	11
Coating Quality Inspection.....	4	Tire Identification and Sorting.....	11
Coating Width Gauging	4	Tire Identification.....	11
End Face Profile Measurement.....	4	Wheel and Tire Assembly.....	12
Assembly	5	Wheel and Lug Nut Torquing.....	12
Electrode Tab Distance Gauging.....	5	Tire Assembly Inspection.....	12
2D Code Reading	5	Safety Systems	13
Stacking Alignment	5	Seat Belt Component Inspection.....	13
Battery Grid Defect Detection.....	5	Seat Belt Fabric Inspection.....	13
Cap Welding Guidance and Inspection.....	6	Brake Valve Component Inspection	13
Battery Surface Inspection	6	Brake Pad Inspection	13
Tab Inspection.....	6	Brake Module Identification	13
Tab Welding Inspection	6	Airbag Fabric Stitching Inspection.....	13
Battery Seal Inspection.....	6	Chassis Systems	14
Battery Pack Welding Inspection.....	6	Gap and Flush Inspection.....	14
Formation	7	Seat Cover Verification Inspection	14
Code Reading.....	7	Weld Seam Inspection.....	14
Pouch Surface Inspection.....	7	Sun Roof Glue Bead Inspection	14
Cell Stacking Height Measurement.....	7	Kitting Process Improvement	14
Battery Optical Character Recognition	7	Cosmetic Assembly Verification	14
Module & Pack System	8	Steering Wheel Pre-Assembly Inspection.....	15
Code Reading.....	8	Trim Final Assembly Verification.....	15
Module and Busbar Welding Inspection.....	8	VIN Code Inspection.....	15
M&P Assembly and Cable Connector Guidance	8	Electronic Systems	16
Final Assembly Verification.....	8	Printed Circuit Board Inspection.....	16
Motor & Inverter	9	Electrical Module Inspection.....	16
Engine Block Optical Character Recognition	9	Wiring Harness Inspection.....	16
PCB Warpage Measurement	9	Transmission Gear Inspection.....	16
Terminal Height Measurement	9	Cognex Global Services	17
Rotor/Stator Inspection.....	9	Cognex Training	18
Seal Profile Measurement.....	10		
RTV Silicone Bead Seal Inspection.....	10		
Oil Seal and O-Ring Assembly Inspection	10		

BATTERY

ELECTRODE

During the electrode manufacturing process, electrode material is coated onto copper and aluminum foil for electric flow. It is essential to check the metal surface, separator, and coating for any surface or edge defects as well as uniform shape and thickness. Cognex provides quality inspection and gauging solutions to ensure that electrode sheets meet exacting specifications before they are separated by an insulator and—depending on manufacturer and form type—rolled, wound, or stacked into a lithium-ion cell.

Coating Quality Inspection

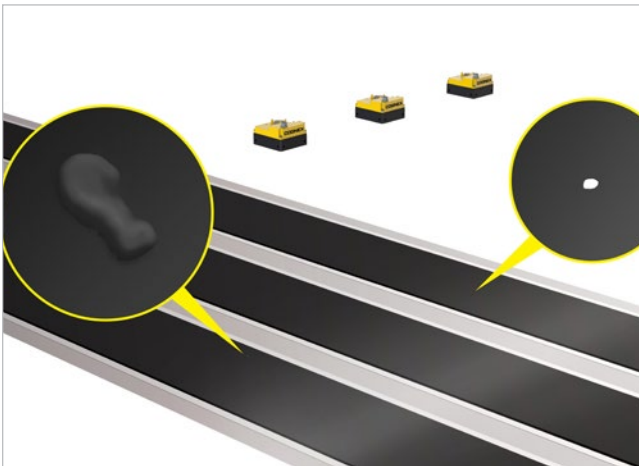

Cognex Industrial Line Scan Cameras and Cognex Deep Learning detects defects like craters, bubbles, and holes on electrode sheets.

Coating Width Gauging

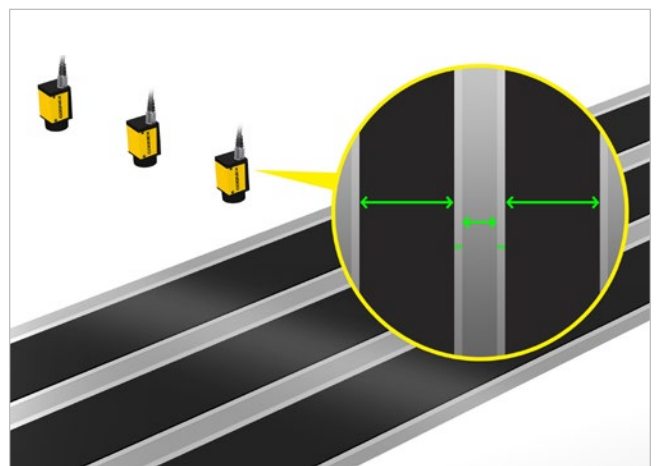

Cognex Industrial Area Scan Cameras and VisionPro® software gauge the dimensions of the separator and electrode.

End Face Profile Measurement

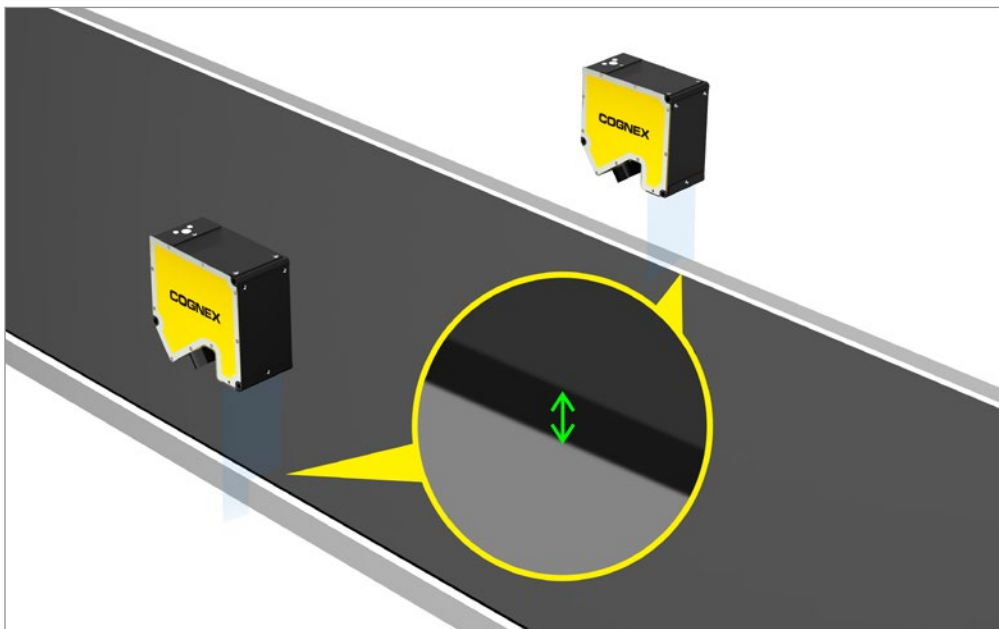

DSMax offers the speed and accuracy necessary to measure the profiles of electrode-coated end faces. DSMMax can continuously measure black electrode coatings, even when wet, to detect any waviness in real time.

ASSEMBLY

In cell assembly, a separator and electrode are joined together during vacuum drying. The joined cell of cathode and anode is either wound, rolled, or stacked. Lead tabs are attached to the folded cells. The process is complete when the cells are filled with electrolytes, vacuum-sealed, and dried. Cognex offers gauging, 2D code reading, alignment, guidance, and inspection solutions to ensure that lithium-ion cells can meet high energy density and performance demands. Cylinder-, pouch-, and prismatic- or can-type cells manufactured with Cognex technology are well-suited to mobile energy storage applications, including as automotive batteries for electric vehicles.

Electrode Tab Distance Gauging

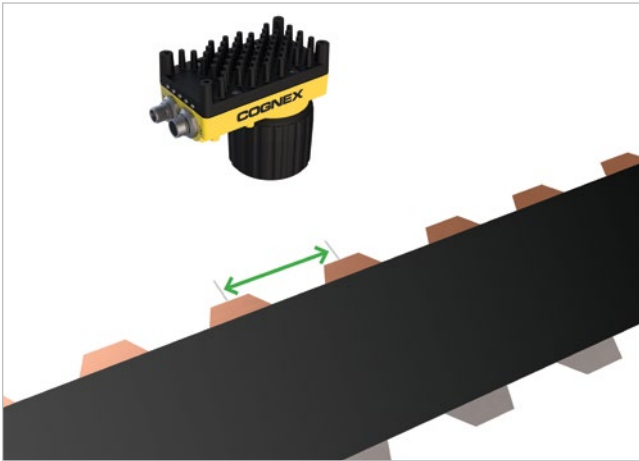

The In-Sight® 5000 vision system measures the distance between poles on a cell sheet.

2D Code Reading

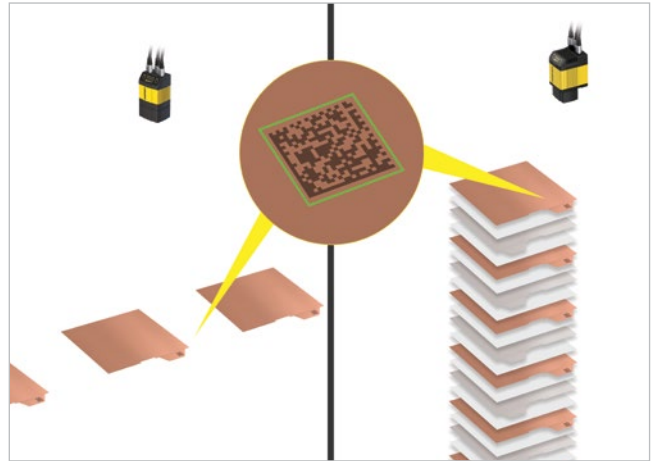

DataMan® image-based barcode readers read laser-etched DataMatrix codes on the copper sides of cell sheets and the top of stacked electrodes.

Stacking Alignment

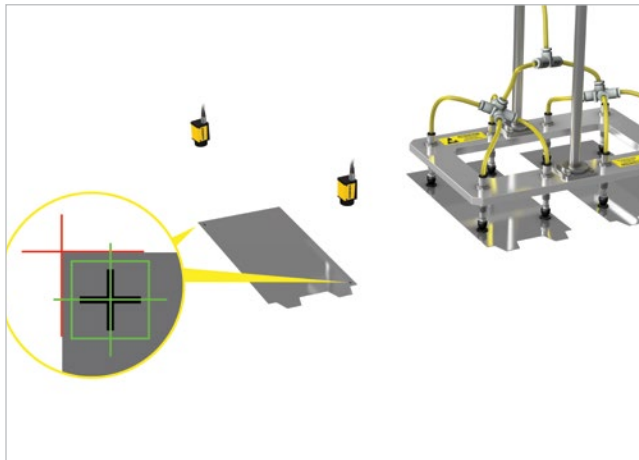

Cognex Industrial Cameras and VisionPro software align cell sheets for stacking.

Battery Grid Defect Detection

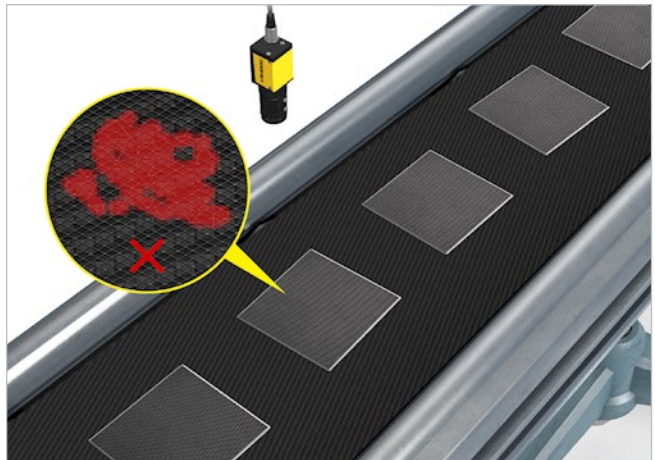

Cognex Deep Learning inspects complex patterns on separating grids for bends, gaps, and other defects before installation.

Cap Welding Guidance and Inspection

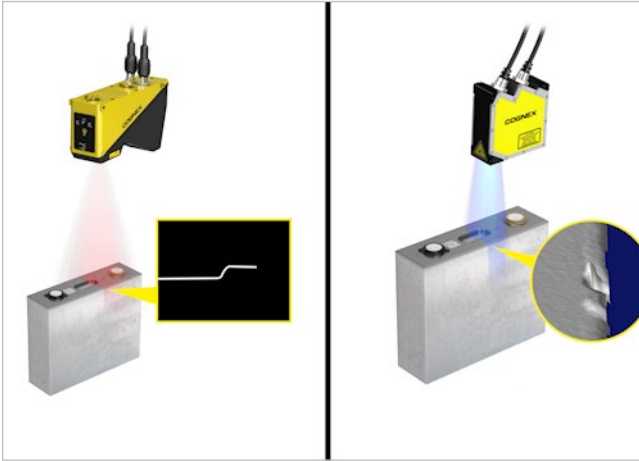

The DS1000 3D laser displacement sensor measures the height difference between the cap and battery case prior to welding. Afterwards, the DS925 laser displacement sensor inspects the welded seams to ensure they are fully sealed and free of defects.

Battery Surface Inspection

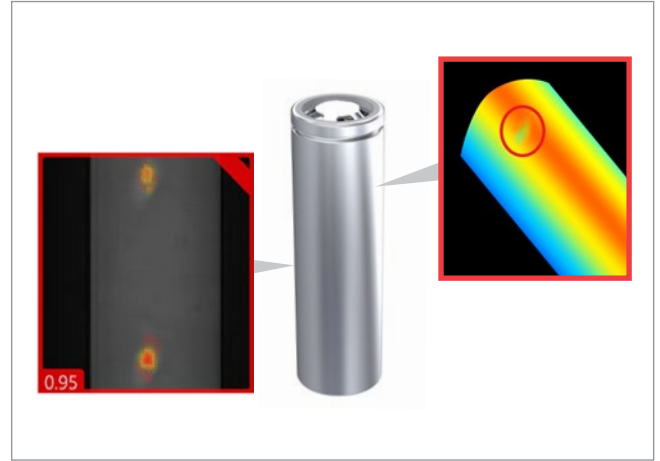

Cognex Deep Learning detects unpredictable cosmetic defects like dents, scratches, or stains on a cylindrical battery can. With Cognex Deep Learning, users can stack 2D and 3D images of cells to analyze them simultaneously.

Tab Inspection

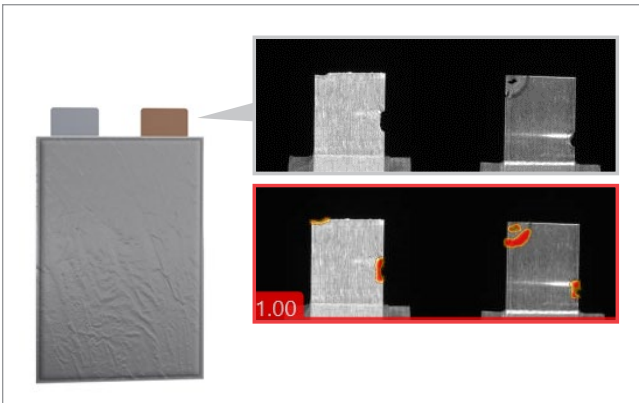

Cognex Deep Learning identifies defects, such as broken edges, holes, or scratches on the tab's surface.

Tab Welding Inspection

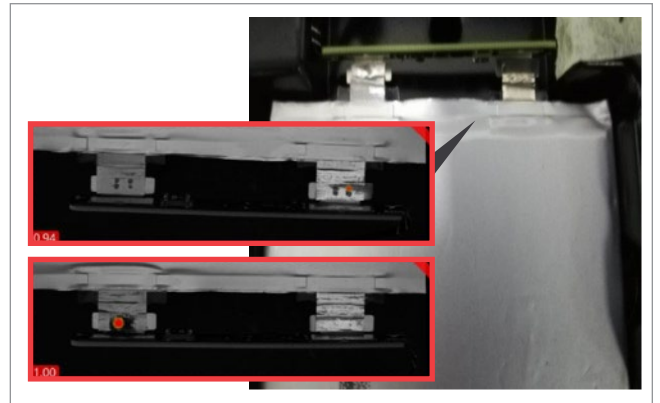

Cognex Deep Learning checks welding quality and finds defects like over-welding, missing welds, or burns on tabs.

Battery Seal Inspection



The DSMax 3D laser displacement sensor inspects the dimensions of battery caps to ensure they are fully sealed and free of defects. DSMax uses a highly accurate telecentric lens to accurately capture grooves and any defects like tilting or uneven height, regardless of the can's color.

Battery Pack Welding Inspection

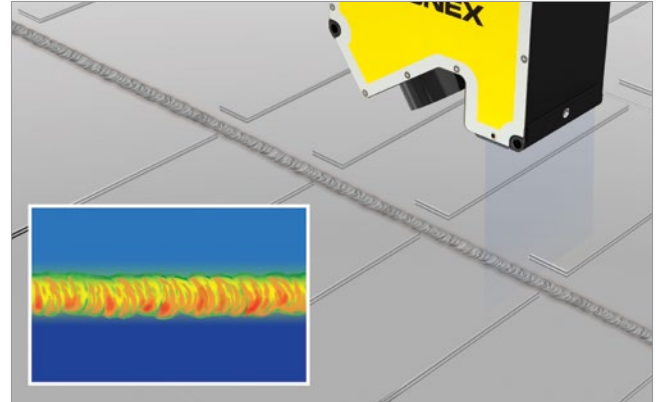

DSMax performs surface measurement of the welds on battery packs. Cognex Deep Learning image analysis helps detect unpredictable weld defects, despite specular glare on challenging metal surfaces.

FORMATION

Lithium-ion cells are activated, packaged, and tested during the formation process. During this process, individual cells are charged to become EV batteries and tested for voltage, current, and cosmetic appearance. Completed EV cells are graded and tracked using barcodes before they are shipped to EV module and pack manufacturers. Cognex offers code reading, pouch surface inspection, cell stacking height measurement, and optical character recognition (OCR) solutions to help manufacturers ensure their lithium-ion cells can meet the demands of large-format battery pack manufacturers and energy storage system developers.

Code Reading

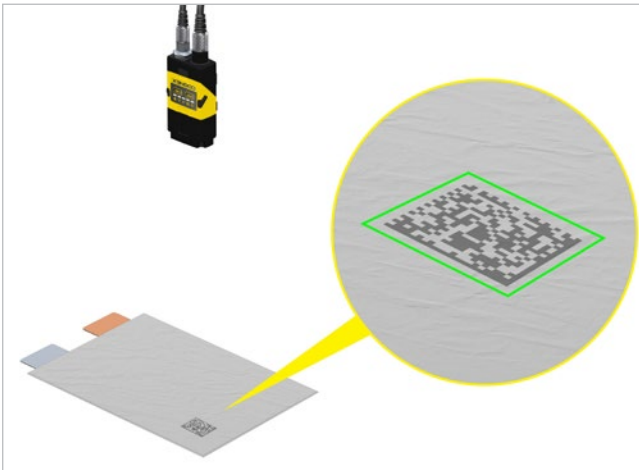

A DataMan 260 image-based barcode reader reads stretched DataMatrix codes on a pouch's surface.

Pouch Surface Inspection

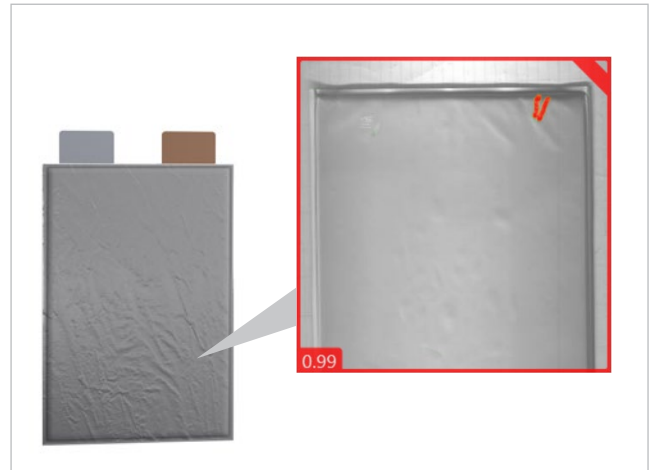

Cognex Deep Learning identifies surface defects, like bubbles and wrinkles, on a pouch's surface.

Cell Stacking Height Measurement

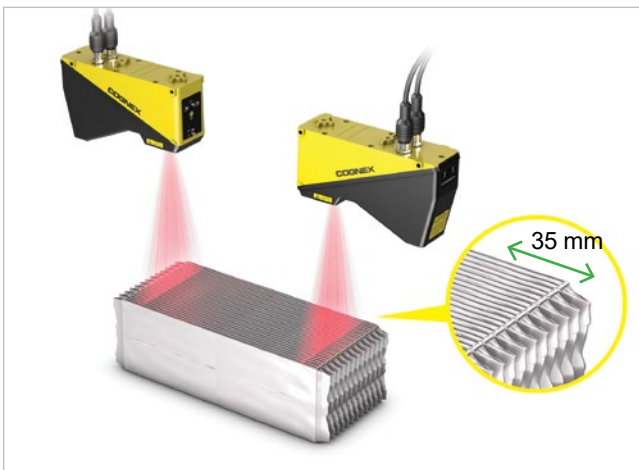

Two DS1000 3D laser displacement sensors measure the profile of cell batteries stacked inside a module.

Battery Optical Character Recognition

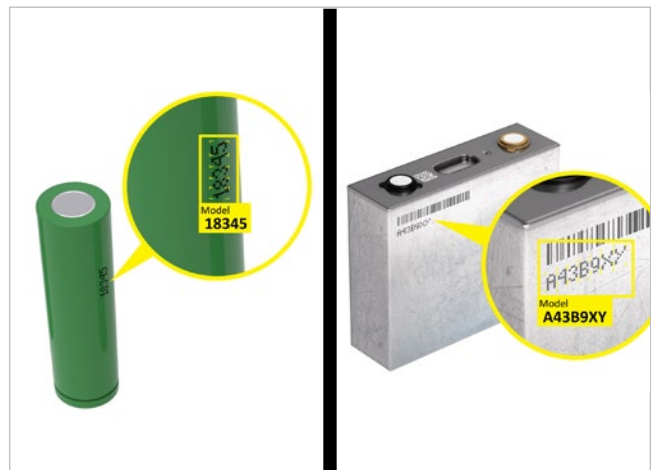

Cognex Deep Learning locates and reads the alphanumeric codes on batteries using a pre-trained font library.

MODULE & PACK SYSTEM

EV module and pack systems are assembled by both OEMs as well as automotive makers. A module is composed of multiple battery cells welded or otherwise physically assembled to each other, wrapped in steel plates, and then its poles welded together to produce the correct voltage. Inspection during the assembly process verifies that both cells and packs are in the correct position, have strong contact, and are properly welded. Cognex offers machine vision solutions for module inspection, busbar welding inspection, module and pack (M&P) assembly, cable connector guidance, and code reading to guarantee proper function before EV modules and packs flow into general assembly.

Code Reading

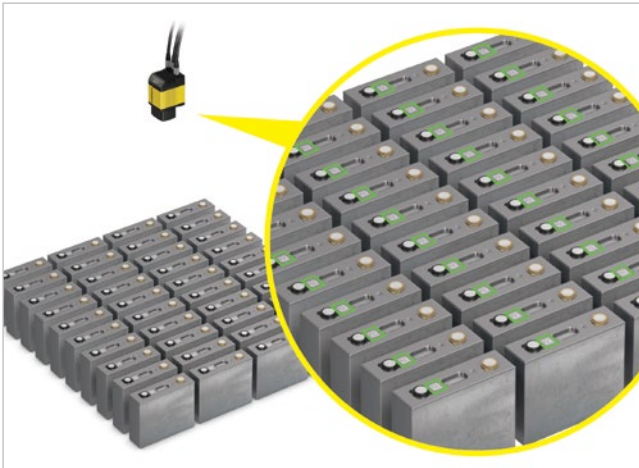

The DataMan 470 barcode reader reads a large array of codes on battery modules during testing.

Module and Busbar Welding Inspection

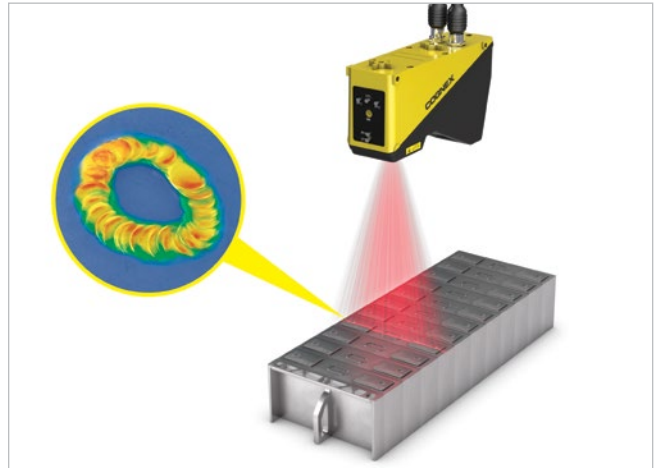

The DS1000 3D laser displacement sensor and Cognex Deep Learning inspect the welds on a battery pack's modules and busbars.

M&P Assembly and Cable Connector Guidance

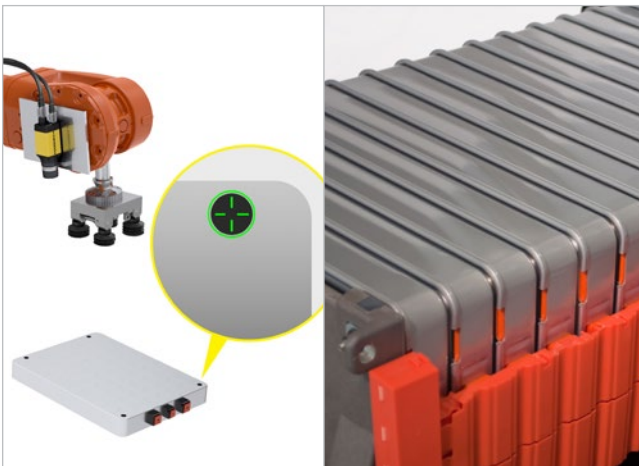

The In-Sight 8000 vision system guides the final assembly of modules and cable connectors into a pack.

Final Assembly Verification

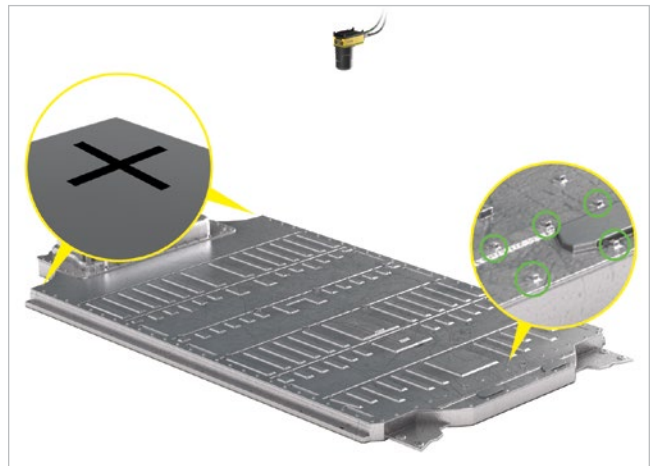

The In-Sight 9912 vision system inspects the final battery pack for completeness and fixtures it for robotic placement.

MOTOR & INVERTER

The motor is the heart of every electric vehicle. The power of this motor depends on the magnetic field that is generated between the rotor and the stator. EVs use three-phase brushless motors for electric propulsion. But, the vehicle drive battery supplies a direct current (DC) so it needs to be converted to a three-phase alternating current (AC) using an inverter. A three-phase inverter, which is composed of power devices, converts DC to AC during acceleration (powering) and converts AC to DC during braking (regeneration). Cognex machine vision solutions and 3D sensors help monitor the thickness of the threads and motor windings, inspect properly sealed seams on the motor, measure PCB warpage and terminal height, and perform oil seal and o-ring assembly verification.

Engine Block Optical Character Recognition

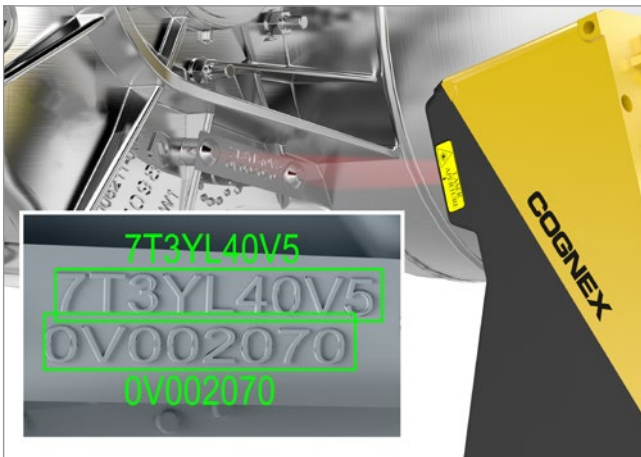

2D and 3D OCR tools read laser-etched characters on surfaces, guaranteeing reliable identification and traceability.

PCB Warpage Measurement

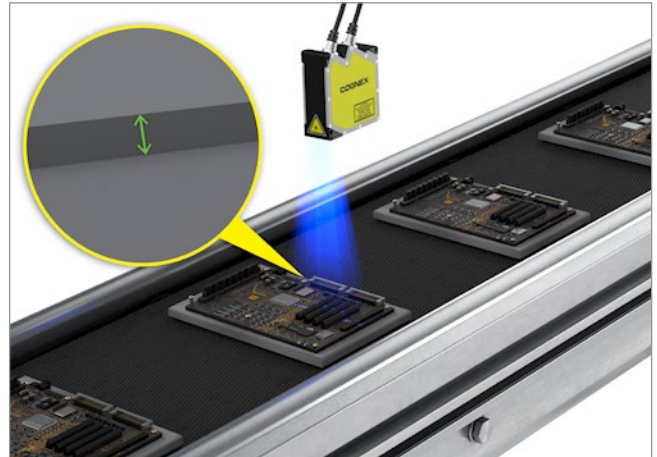

A laser displacement sensor measures the height difference between the carrier and the printed circuit board (PCB) to inspect for warpage. The sensor does this while in continuous motion, speeding inspection.

Terminal Height Measurement



Inverter terminals have very complex terminals, which require 3D inspection. A laser displacement sensor measures the height profiles of connectors to make sure they are coplanar.

Rotor/Stator Inspection

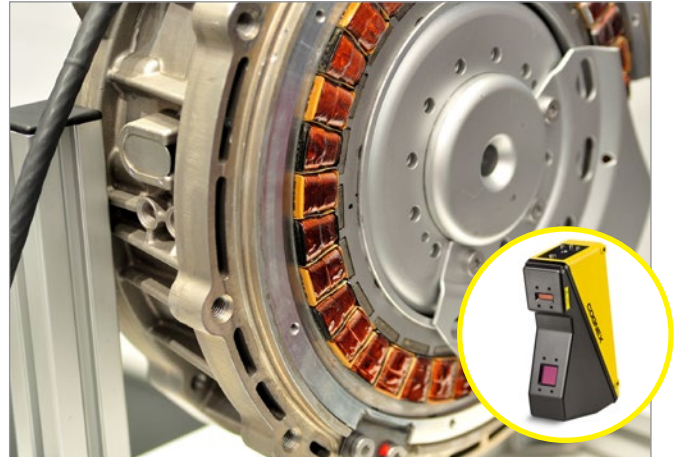

A DS1000 3D laser displacement sensor performs in-line inspection of the narrow gap between rotor and stator, and assesses wedge tightness for the magnetic field.

Seal Profile Measurement

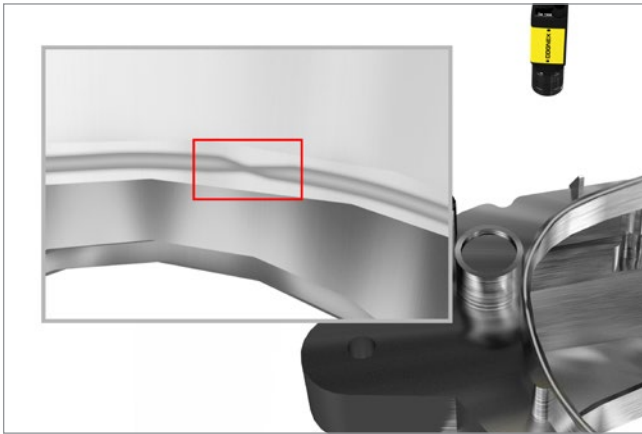

The BeadInspect™ tool inspects the glue beads around the edges of the motor to detect any improperly sealed seams, which could cause oil leakage.

RTV Silicone Bead Seal Inspection



The BeadInspect vision tool inspects the critical dimensions and placement of glue beads.

Oil Seal and O-Ring Assembly Inspection

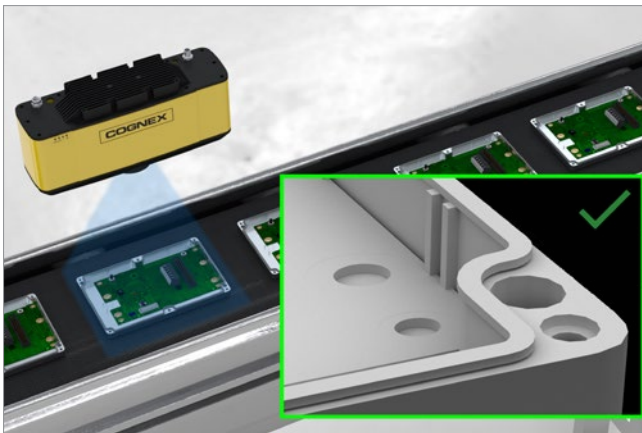

A 3D-A5000 area scan 3D system performs in-line inspection of an oil seal and o-ring, confirming they are set in the correct position in order to prevent water and oil leakage.

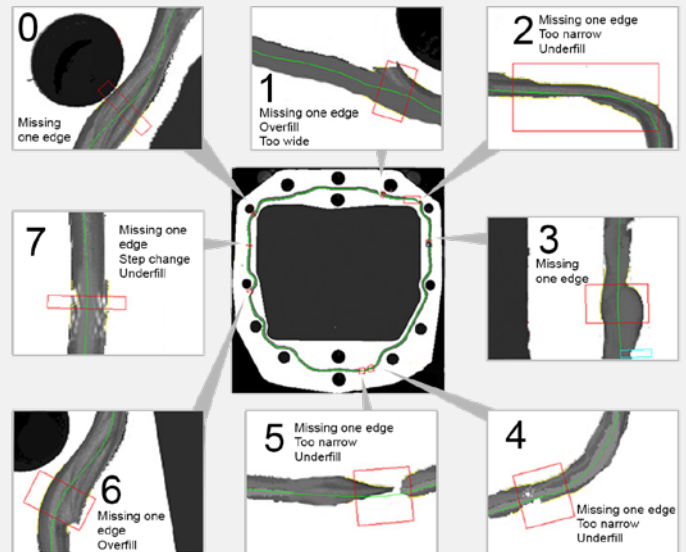

BEAD INSPECTION

BeadInspect is an all-in-one bead width and position inspection tool used to detect anomalies. BeadInspect offers a robust inspection of the bead line—even if bead size, shape, and appearance change over time. This is important when inspecting a freshly applied, wet, or shiny RTV bead, or when beads vary in location from part to part.

Bead inspection with the Cognex BeadInspect tool helps guarantee that glue beads have been dispensed to the correct volume and precise placement. For 2D inspections, the tool locates the position of a glue bead on a part surface and detects gaps. For 3D inspections, it calculates glue bead volume to ensure that the correct amount of glue has been dispensed.

- Easily train the bead path with just a few clicks, using the PolyLine function
- Find defects in beads that change or differ in shape
- Determine width based on defects and gaps
- Remove noise for increased robustness

GENERAL ASSEMBLY

Almost every system and component in an electric vehicle can be made better using machine vision. 2D and 3D machine vision systems gauge chassis parts with high accuracy and inspect and verify assembled vehicle doors, trim, and bodies. 3D vision systems also help chassis manufacturers automate racking and inspect body panels in order to detect defects prior to welding.

TIRE AND WHEEL SYSTEMS

Deliver robust, high-speed, wheel identification using propriety code-reading algorithms that can reliably locate codes despite random placement and orientation of wheels on a conveyor. Alphanumeric character reading vision tools enable tire manufacturers to read codes in the most challenging conditions with very high accuracy. PatMax, a geometric pattern matching tool, learns tire tread patterns and has the flexibility to adapt to the positional variation of tires on a conveyor, ensuring that manufacturers assemble the correct wheel to a vehicle.

Tire Identification and Sorting



3D laser displacement sensors identify tires by DOT code.

Tire Identification



Image-based barcode readers with high speed liquid lenses rapidly read codes at different heights on tires, regardless of orientation.

ANY CODE, EVERY TIME

2DMax with PowerGrid reads 2D codes with significant damage to or complete elimination of a code's finder or clocking pattern, or quiet zone.

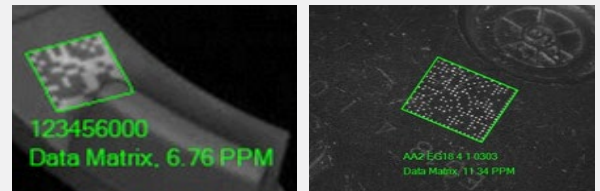

1DMax with Hotbars is an algorithm and technology optimized for omnidirectional 1D barcode reading, decoding up to 10X the speed of a conventional barcode reader.



OCRMax™, a font-trainable Optical Character Recognition and Verification (OCR and OCV) tool, has set industry records for ease of use, read rates and speed in complex images. This powerful algorithm prevents misreads, handles process variations, and provides easy font management.

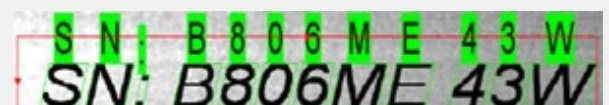

Wheel and Tire Assembly



In-Sight 7000 vision systems identify wheels by pattern and match them to tires.

Wheel Lug Nut Torquing



Machine vision systems guide robotic arms to help locate and properly torque a wheel's lug nuts.

Tire Assembly Inspection



3D laser displacement sensors verify treads' critical dimensions.

INDUSTRY LEADING OBJECT LOCATION

PatMax RedLine

PatMax RedLine™ is an accurate, highly repeatable tool that locates trained patterns no matter the size, rotation, or location of the target part. It is ideal for industries and applications that require large fields of view, high accuracy, large angle and scale tolerances, and multiple targets.

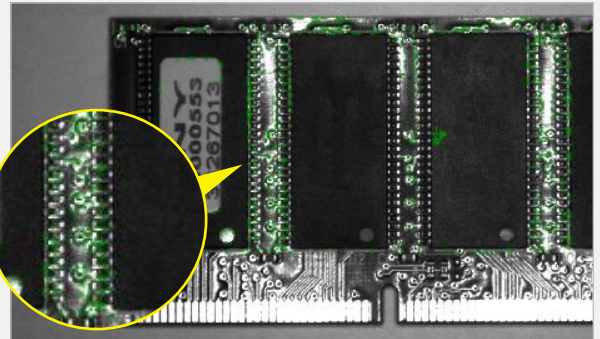

PatMax 3D

PatMax® 3D is an accurate 3D vision tool that locates trained patterns based on its 3D geometry under 6 degrees of freedom (X, Y, Z, Rx, Ry, Rz). It finds 3D objects within a 3D point cloud image and is ideal for locating and identifying objects which are tilted, stacked or not properly seated with a fixture.

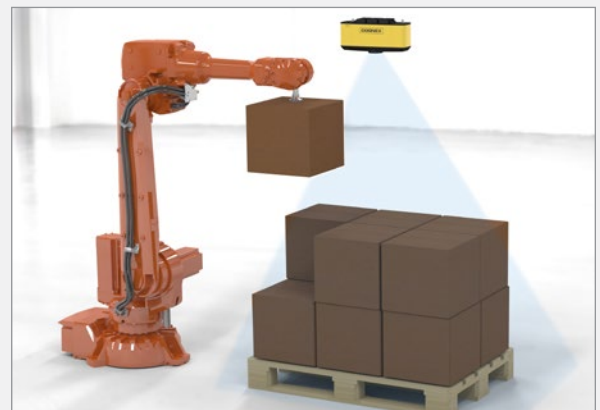
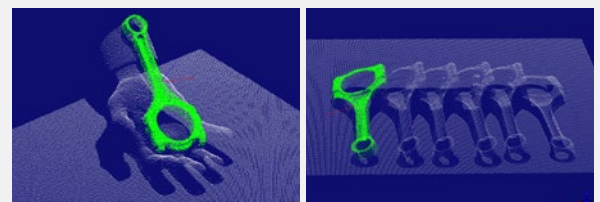

SAFETY SYSTEMS

Image-based barcode readers and machine vision systems help automotive manufacturers control traceability of final assemblies, improve product quality by performing automated component inspections to meet strict quality standards, and measure critical dimensions and part locations with high accuracy to verify that all of the correct components have been properly assembled. This mitigates, for example, the risk of defective braking systems reaching the vehicle assembly plant and minimizes the chance of part recalls.

Seat Belt Component Inspection

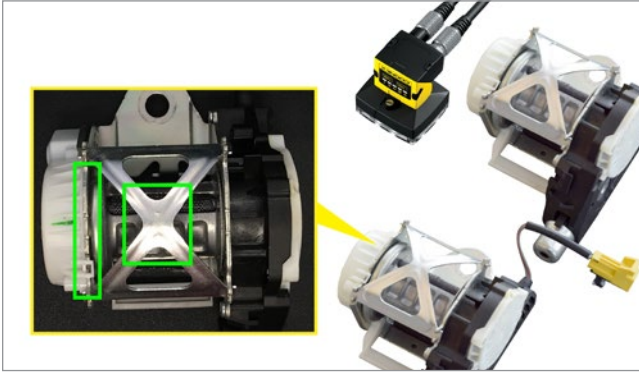

In-Sight 2000 vision sensors confirm the presence of critical features and dimensions of seat belt components prior to assembly.

Seat Belt Fabric Inspection

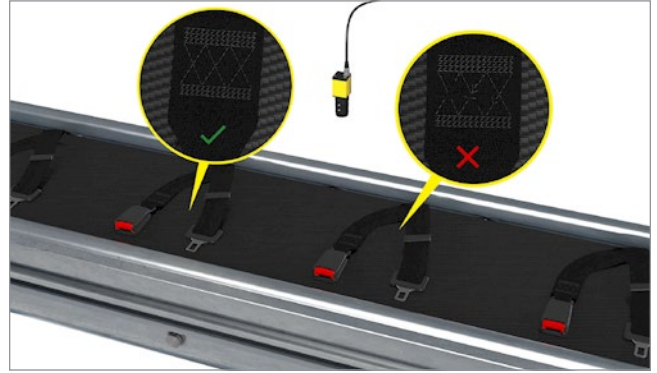

Cognex Deep Learning inspects seat belt fabric weave and stitching for defects and other unwanted anomalies.

Brake Valve Inspection



Machine vision systems inspect threads, features, length, and surface finish to verify that valves are made correctly.

Brake Pad Inspection

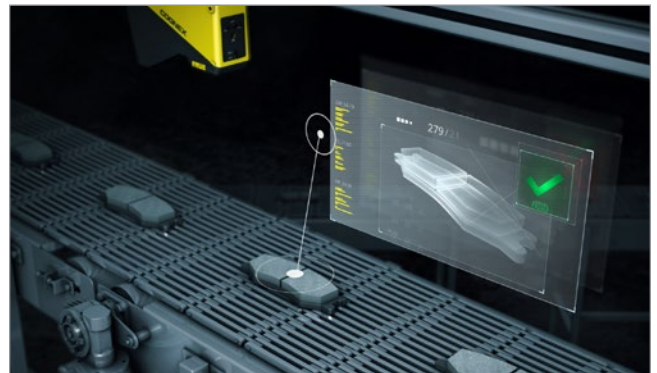

3D displacement sensors inspect brake pad rivets and verify dimensions.

Brake Module Identification

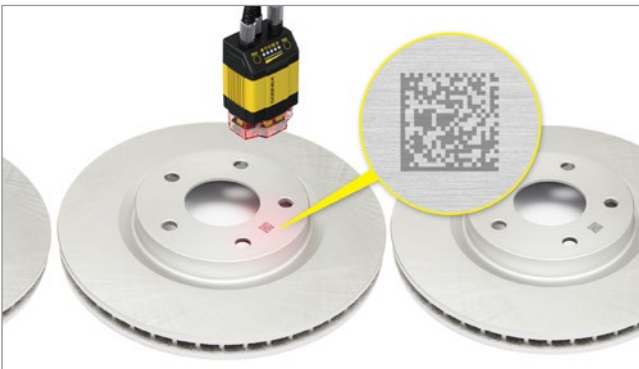

Barcode readers identify components for the brake assembly, even on highly reflective surfaces.

Airbag Fabric Stitching Inspection



Deep learning-based image analysis inspects the stitching on airbag fabric and stitching for defects.

CHASSIS SYSTEMS

A Cognex 3D vision system, either mounted in a fixed position or on a robot, can measure the gap and flush of every car with high accuracy and provides complete inspection of all assembled vehicle doors and bodies. A 3-D vision systems also helps chassis manufacturers automate racking, de-racking and inspection of body panels in supply racks and detect part defects in the racks before defective parts are picked up by a robot thus eliminating defective parts being welded together.

Gap and Flush Inspection

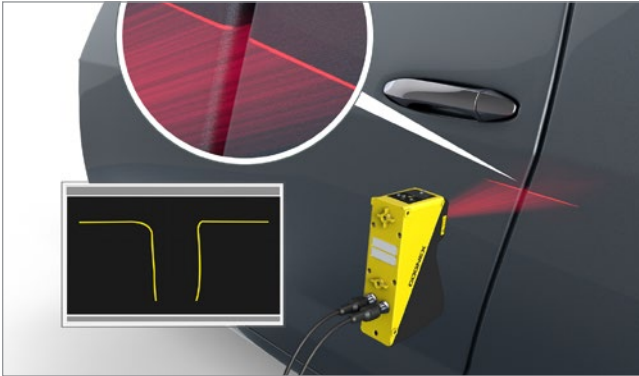

Laser profilers assess the height and alignment of assembled vehicle doors and bodies.

Seat Cover Verification Inspection



Cognex Deep Learning confirms that the right covers have been correctly installed on automotive seats.

Weld Seam Inspection

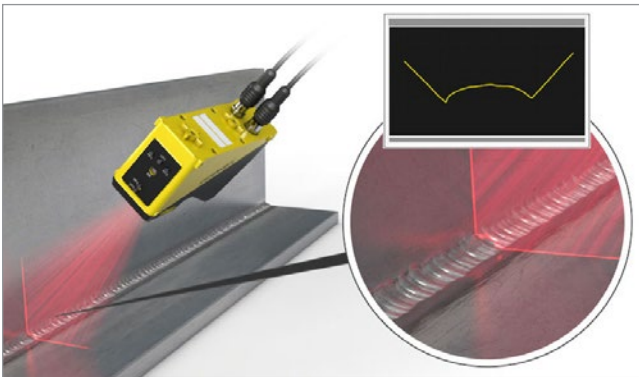

DS1000 3D laser displacement sensors inspect the welding seams of metal components before they are painted.

Sun Roof Glue Bead Inspection

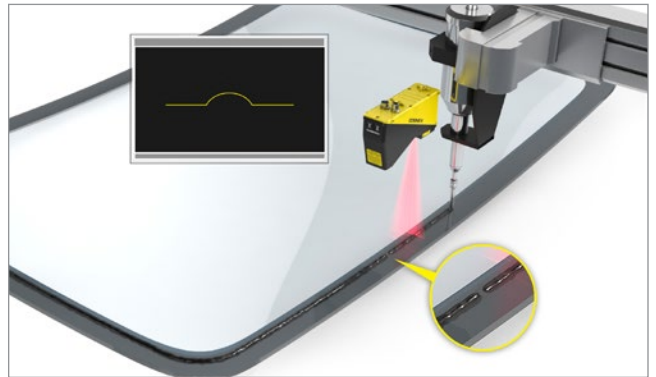

The In-Sight Laser Profiler measures glue bead volume to ensure the correct amount of glue has been dispensed.

Kitting Process Improvement



Barcode readers verify that a kit contains the correct parts.

Cosmetic Assembly Verification



A machine vision system verifies the presence, proper spacing, alignment, and completeness of a dashboard.

Steering Wheel Pre-Assembly Inspection

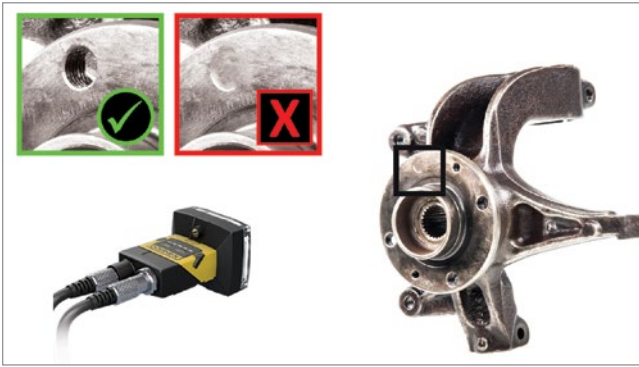

Vision sensors inspect steering wheel knuckles prior to module assembly.

Trim Final Assembly Verification

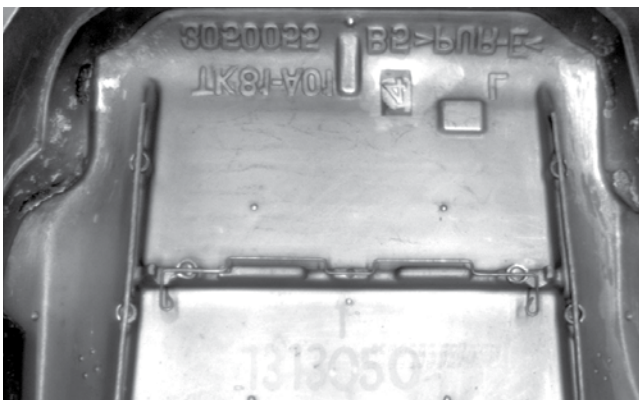

Wire present

No wire

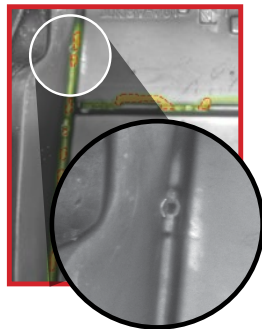
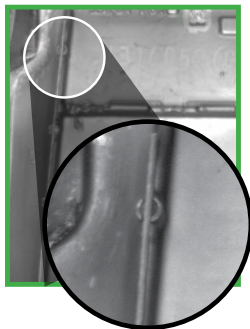

Deep learning-based image analysis verifies the presence of components on a confusing surface during final assembly.

VIN Code Inspection



Deep learning-based image analysis reads the deformed characters marked on a VIN code.

COGNEX DEEP LEARNING

Deep learning technology uses neural networks that mimic human intelligence to distinguish anomalies, locate deformed parts, and read challenging characters while tolerating natural variations in complex patterns. Deep learning complements traditional machine vision approaches, which struggle to appreciate variability and deviation between visually similar parts. In factory automation, Cognex Deep Learning can now perform judgment-based part location, inspection, classification, and character recognition more effectively than humans or traditional machine vision solutions.

Finds and counts complex features and objects

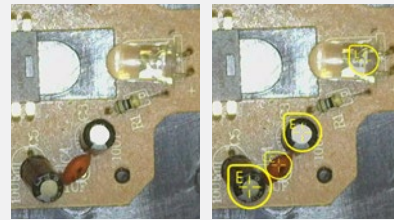

Classifies and sorts objects and complete scenes

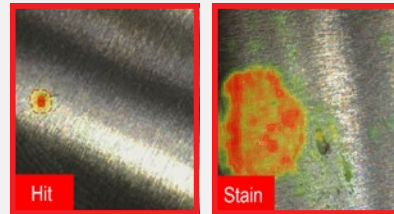

Detects anomalies and cosmetic defects

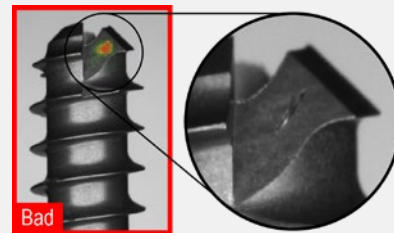

Reads challenging, deformed characters

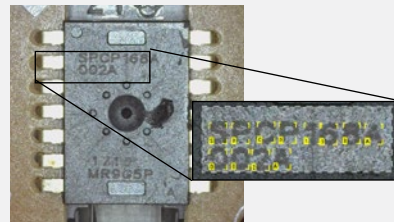

ELECTRONIC SYSTEMS

Across a range of applications, Cognex vision tools provide micron-level accuracy to ensure reliable electronics performance in automobiles and increase inspection speed for greater scale. For instance, speed up and error proof the component sorting process through vision tools with color and shape recognition and pattern matching tools; inspect for defects including damaged parts and missing features; automatically inspect solder joint connections and analyze the shape of the solder to ensure it meets rigorous tolerances; measure glue bead width and volume to detect any bead gaps in sealing gaskets on electrical modules.

Printed Circuit Board Inspection



Barcode readers identify and sort electrical components.

Electrical Module Inspection



Machine vision systems inspect electrical modules for color and quality prior to assembly.

Wiring Harness Inspection

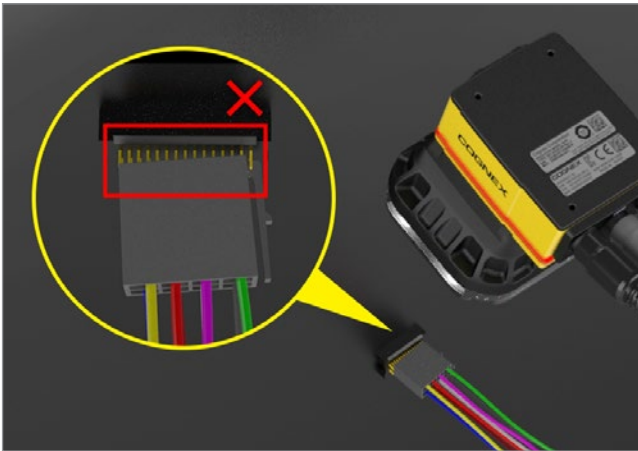

In-Sight 7000 vision systems confirm that wiring harnesses are properly seated.

Transmission Gear Inspection

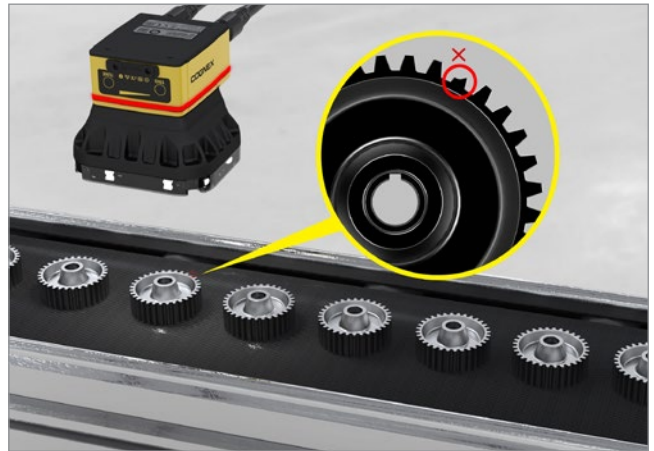

In-Sight 7000 vision systems gauge the dimensions of transmission gears and inspect for damage.

COGNEX GLOBAL SERVICES

Customers get more than software when they purchase from Cognex. They get a company focused exclusively on machine vision, with the most comprehensive application experience. Add direct, high-quality worldwide service and support, and it's easy to see why Cognex is the machine vision company that industries rely on.

Technical Support
Product Training
Hardware Programs
Product Lifecycle

When it comes to protecting your machine vision investment, Cognex understands that responsive, expert service is an expectation all customers should have. Cognex serves an international customer base from offices located throughout the Americas, Europe, and Asia and through a global network of highly-trained partners, system integrators, and distributors.

From development to deployment, Cognex is there to help you get your vision systems up and running as fast as possible. Whether you're considering machine vision for the first time or are already an expert user, Cognex global services provide the expertise to help your organization succeed.

cognex.com/support/Cognex-services



OFFICES IN

20+

COUNTRIES

500+

**GLOBAL PARTNERS
IN 30 COUNTRIES**

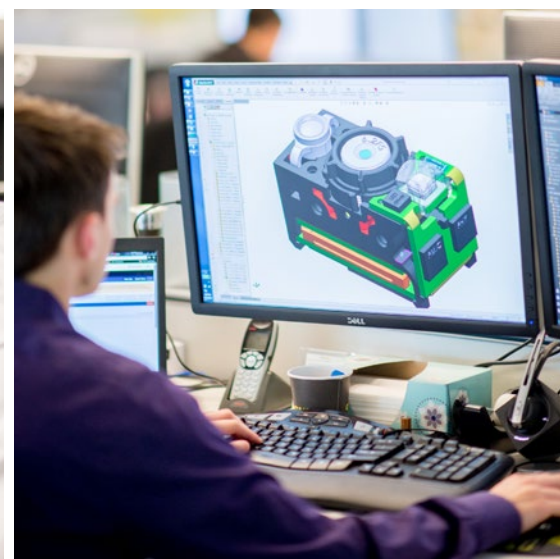

COGNEX TRAINING

We want to make YOU the most effective vision professional at your organization. Cognex offers a variety of training options dedicated to optimizing manufacturing processes and increasing organizational expertise. Through its global training organization, Cognex operates classroom facilities that deliver a variety of courses lasting 1–4 days for beginners to advanced users. Topics include the fundamentals of machine vision to real-world applications for complex tools.



Customized, Anytime

For groups of six or more, all Cognex classes are available at YOUR FACILITY so that your team can work and learn together in your own real-world environment. For on-demand convenience, the Cognex online training portal lets you access on-demand training videos of many Cognex courses, participate in online courses, view tutorials, examine application examples, and watch lighting and optics videos.

By combining key training classes and system integration services into training service packages, Cognex can help focus and accelerate your learning.

Our three most popular packages—Building Vision Competence, Upgrading Vision System, and Factory Level Service Program (FLSP)—address common customer challenges and can be customized to suit your specific needs.

www.cognex.com/training



10,783

ATTENDEES IN 2020



1074

WORLDWIDE CLASSES
IN 2020



18

DIFFERENT LANGUAGES

BUILD YOUR VISION

2D VISION

Cognex machine vision systems are unmatched in their ability to inspect, identify and guide parts. They are easy to deploy and provide reliable, repeatable performance for the most challenging applications.

www.cognex.com/machine-vision



3D VISION

Cognex In-Sight laser profilers and 3D vision systems provide ultimate ease of use, power and flexibility to achieve reliable and accurate measurement results for the most challenging 3D applications.

www.cognex.com/3D-vision-systems



VISION SOFTWARE

Cognex vision software provides industry leading vision technologies, from traditional machine vision to deep learning-based image analysis, to meet any development needs.

www.cognex.com/vision-software



BARCODE READERS

Cognex industrial barcode readers and mobile terminals with patented algorithms provide the highest read rates for 1D, 2D and DPM codes regardless of the barcode symbology, size, quality, printing method or surface.

www.cognex.com/BarcodeReaders



COGNEX

Companies around the world rely on Cognex vision and barcode reading solutions to optimize quality, drive down costs, and control traceability.

Corporate Headquarters One Vision Drive Natick, MA 01760 USA

Regional Sales Offices

Americas

North America +1 844-999-2469
Brazil +55 11 4210 3919
Mexico +800 733 4116

Europe

Austria +49 721 958 8052
Belgium +32 289 370 75
France +33 1 7654 9318
Germany +49 721 958 8052

Hungary +36 800 80291
Ireland +44 121 29 65 163
Italy +39 02 3057 8196
Netherlands +31 207 941 398
Poland +48 717 121 086
Spain +34 93 299 28 14
Sweden +46 21 14 55 88
Switzerland +41 445 788 877
Turkey +90 216 900 1696
United Kingdom +44 121 29 65 163

Asia

China +86 21 6208 1133
India +9120 4014 7840
Japan +81 3 5977 5400
Korea +82 2 530 9047
Malaysia +6019 916 5532
Singapore +65 632 55 700
Taiwan +886 3 578 0060
Thailand +66 88 7978924
Vietnam +84 2444 583358

© Copyright 2021, Cognex Corporation.
All information in this document is subject to change without notice. All Rights Reserved. Cognex, VisionPro, In-Sight, DataMan, PatMax, 2DMax, PowerGrid, 1DMax, and Hotbars are registered trademarks of Cognex Corporation. PatMax RedLine, SurfaceFX, LineMax, and OCRMax are trademarks of Cognex Corporation. All other trademarks are property of their respective owners. Lit. No. EVSG-05-2021

www.cognex.com