

**COGNEX**

Advanced machine vision made easy

# Compact, fully embedded vision system powered by AI

**In-Sight 8900 Series**



# Automate defect detection and track-and-trace processes while meeting regulatory requirements

## In-Sight 8900 Series

The In-Sight 8900 is an ultra-compact, AI-powered vision system designed for OEMs in highly regulated industries. Advanced AI capabilities and powerful imaging enable precise, automated inspections, ensuring product quality and minimizing the risk of recalls. With fully integrated functionality and features that support compliance, the In-Sight 8900 simplifies deployment and offers complete 21 CFR Part 11 readiness, making it the ideal solution for regulated environments.



# Application examples

The In-Sight 8900 performs a wide range of critical inspection processes in pharmaceutical and medical device manufacturing, the automotive industry, and more.

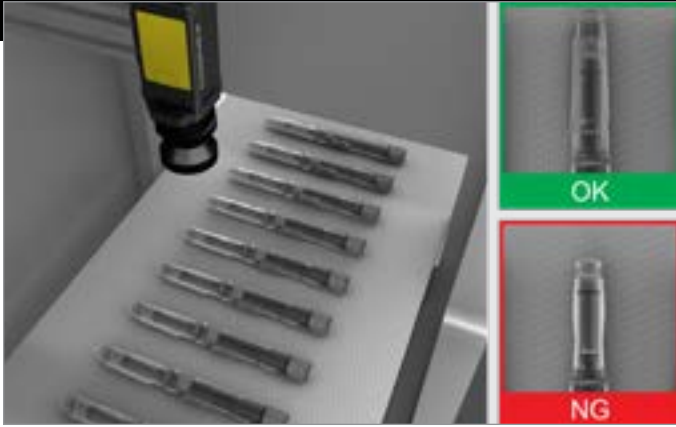

**Inspection:** Detect defects, such as incorrect markings, missing components, or printing errors, to comply with quality standards



**Presence/absence detection:** Identify damaged or missing components to ensure product integrity

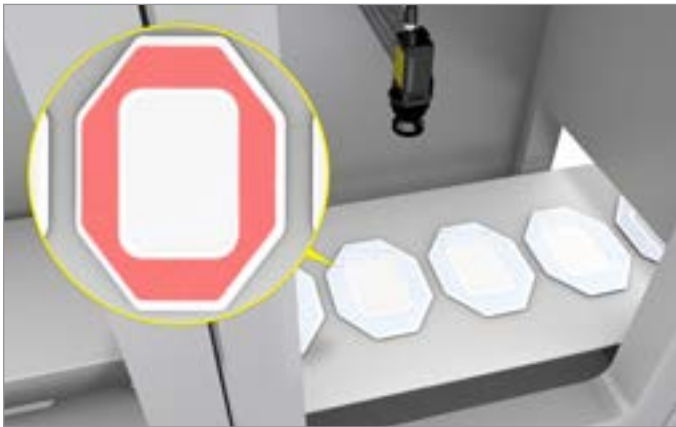

**Assembly verification:** Verify components are present, correctly positioned, and fully assembled during the final stages of production

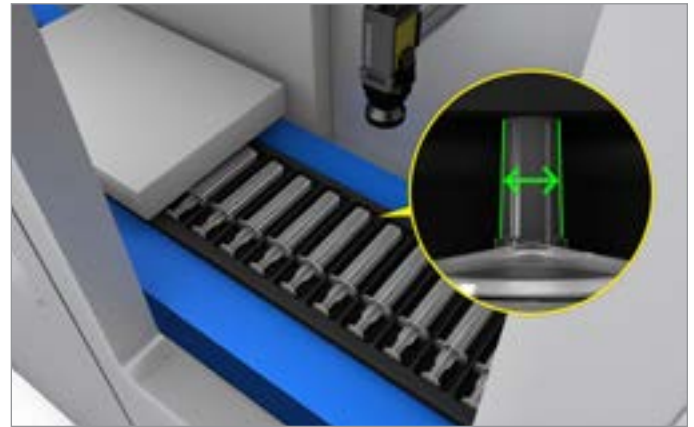

**Measurement:** Gauge the width of products to ensure they meet specifications and maintain consistency



**Automotive text reading:** Read lot codes and various text types, including distorted, angled, or direct part-marked characters, for accurate parts tracking



**Packaging track and trace:** Decode a range of barcodes for reliable, end-to-end traceability

# Supporting end-to-end 21 CFR Part 11 readiness



## Audit Logging

- **Comprehensive Tracking:** Automatically log operator actions with date and time stamps.
- **Efficient Record Retrieval:** Easily locate and obtain records for review.
- **Data Integrity:** Safeguard data by ensuring changes do not overwrite existing record.



## Single Sign-on (SSO)

- **Centralized Management through Microsoft Windows:** Secure access with one set of credentials, eliminating the need for multiple passwords and simplifying authentication.
- **Controlled Access:** Restrict system access to authorized users only.
- **Verified Identity:** Confirm the identity of individuals who electronically sign records.
- **Secure Authentication:** Protect against unauthorized access.
- **User-Specific Settings:** Customize default views for different users for more discrete control.

## Ensuring regulatory compliance across the product portfolio

Cognex offers a variety of vision systems that are 21 CFR Part 11 ready, allowing you to choose the solution that best suits your application or environment.

- In-Sight 2800
- In-Sight L38
- In-Sight 3800
- In-Sight 8900



# Complete vision toolset solves tasks of any complexity

The In-Sight 8900 integrates AI and rule-based tools into a single vision system, making it flexible enough to handle a wide range of error-proofing applications. Use the tools individually for simple tasks or combine them to tackle more complex automation challenges.

## AI tools

The In-Sight 8900 uses AI-powered edge learning tools to process images directly on device and deliver accurate results in real time. With example-based training and no experience needed, these tools offer high ease of use and fast deployment.

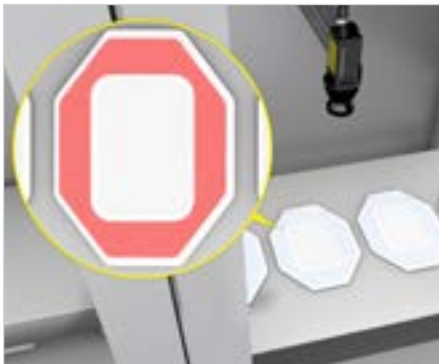

### Segmentation

Extract defects, regions, and objects from complex parts and backgrounds.



### Classification

Detect and sort parts based on multiple features or characteristics.



### Optical character recognition (OCR)

Read characters on reflective, low-contrast, and non-flat surfaces, including multi-line text.

## Rule-based vision tools

The In-Sight 8900 is also embedded with an extensive library of industry-proven traditional vision tools and algorithms including: Measure Distance, Pixel Count, Count Patterns, Math and Logic Tools, and more.



# Common software platform offers flexible development options

In-Sight Vision Suite software is common across all In-Sight products and includes two programming environments — spreadsheet and EasyBuilder®. Start with EasyBuilder, a wizard-like training interface designed for simplicity, and transition to more advanced, spreadsheet programming. In-Sight Vision Suite uniquely integrates these two approaches, providing a seamless experience within the same platform that allows users to efficiently scale their automation.

## Spreadsheet facilitates deployment of advanced applications

The spreadsheet interface is ideal for building complex and highly customized applications. Robust in design, this development environment gives users the ability to make critical adjustments to job parameters and quickly adapt applications to address new requirements.

Powerful **spreadsheet** interface allows users to solve complex applications

	A	B	C	D	E	F	G	H	I
0	Image								
1									
2	PatMax								
3	LPatMax	1.000							
4		Index	X	Y	Angle	Scale	Score		
5	OPatMax	0.000	564.451	342.308	0.059	100.000	59.819		
6									
7	VIDI EL Classify								
8		Health	Num Class	Index	Label	Num Image	Score		
9	VIDI EL Classify	99.892	5.000	0.000	Blueberry	6.000	99.949	<input checked="" type="checkbox"/> Collect Samples	
10				1.000	Damaged	5.000	0.373		
11				2.000	Lemon	6.000	0.369		
12				3.000	Strawberry	6.000	0.309		
13				4.000	Missing	6.000	0.000		
14					Unlabeled	6.000			
15									

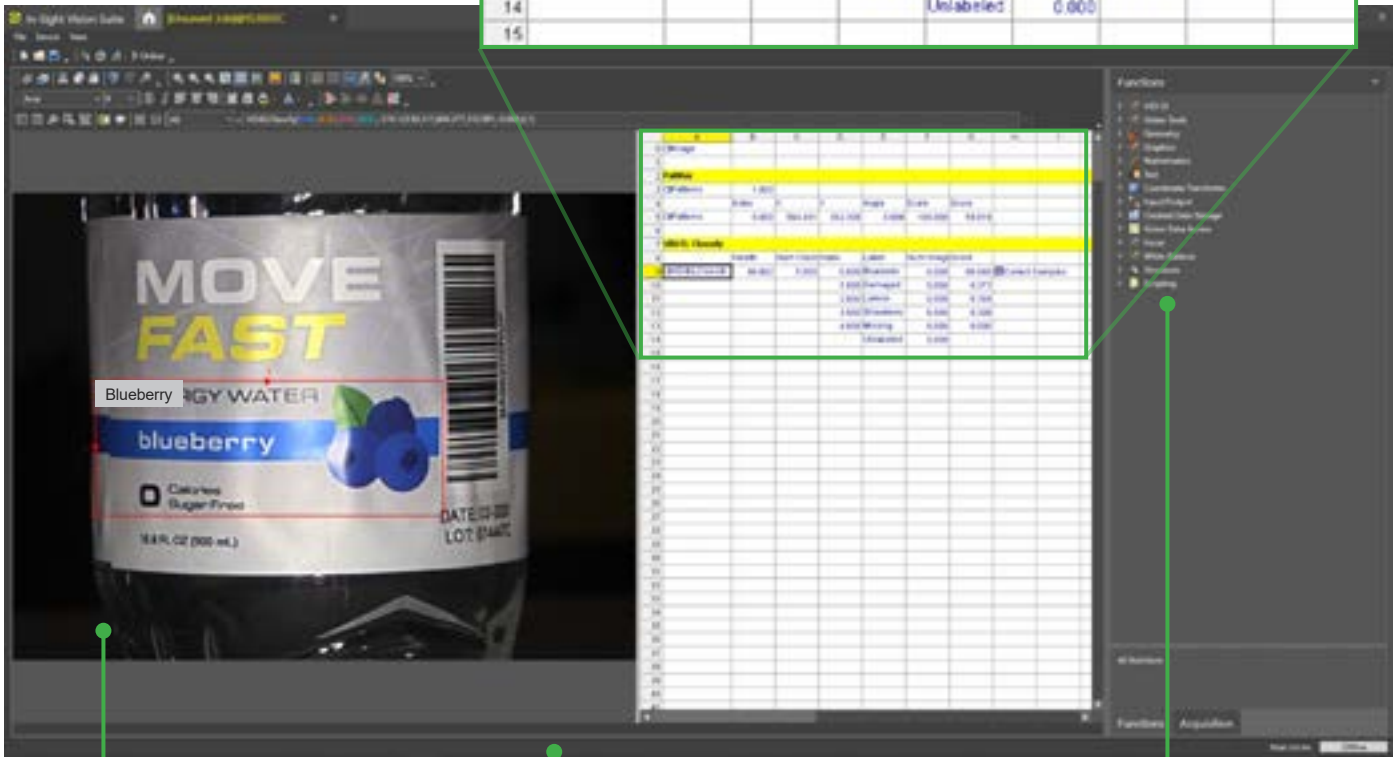

**Easily review and recall files** with image playback

**Full I/O and communications** function set streamlines factory integration

Full suite of AI- and rule-based **vision tools**

# EasyBuilder development environment simplifies setup

With point-and-click training, the EasyBuilder interface within In-Sight Vision Suite is ideal for setting up simple or common jobs. The intuitive process guides users step-by-step through setup—from image capture to the final result and beyond—allowing both new and experienced developers to configure reliable vision applications.

Easy **step-by-step** application setup

Image-centric **point-and-click** functionality allows users to quickly set up tools

Capture images live or upload existing libraries

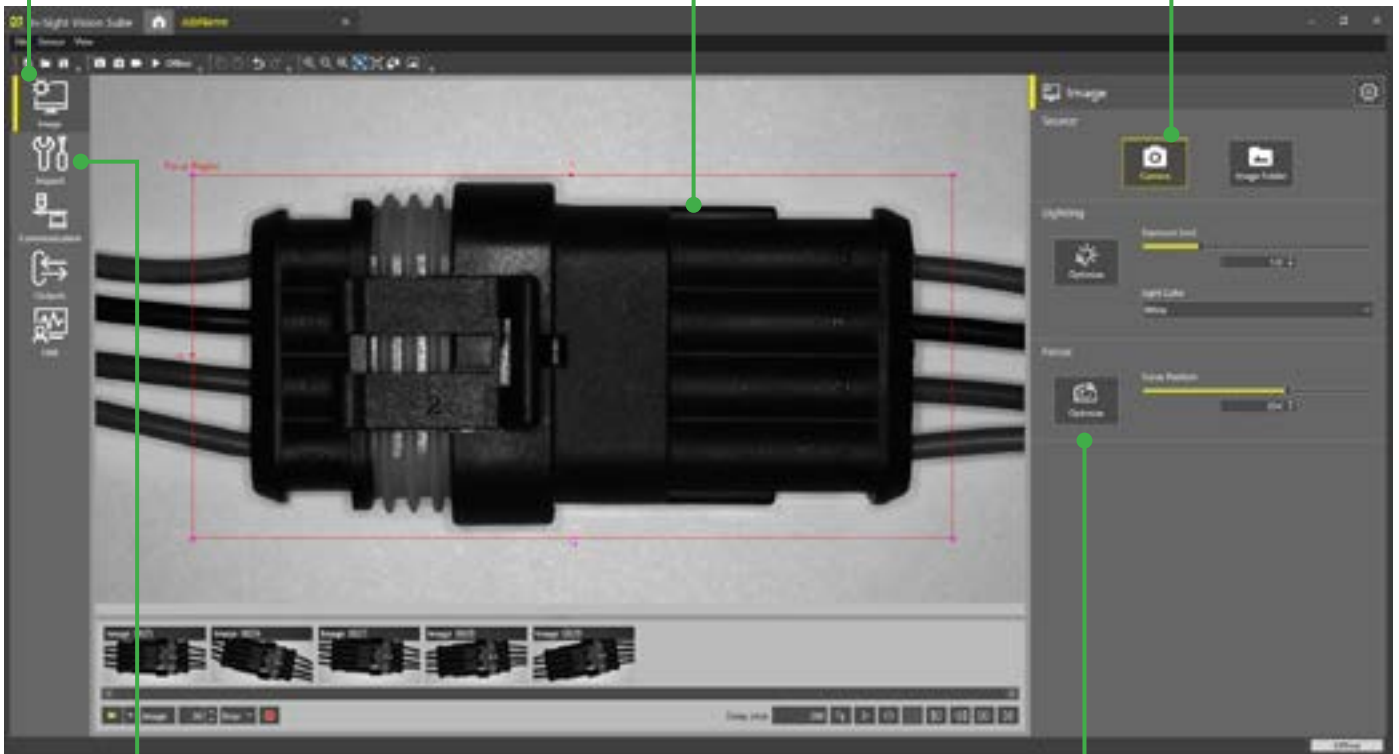

Comprehensive set of traditional rule-based vision tools and **innovative edge learning tools**

Fast, **2-click** image formation

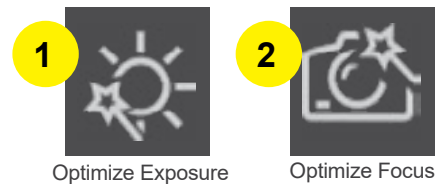

# Web-based HMI offers real-time application testing and optimization

The In-Sight 8900 provides access to a web-based human-machine interface (HMI) that enables runtime visualization. From the HMI, users can view inspection results and modify setup parameters to optimize their application.

EasyView displays tags from jobs in a simplified format

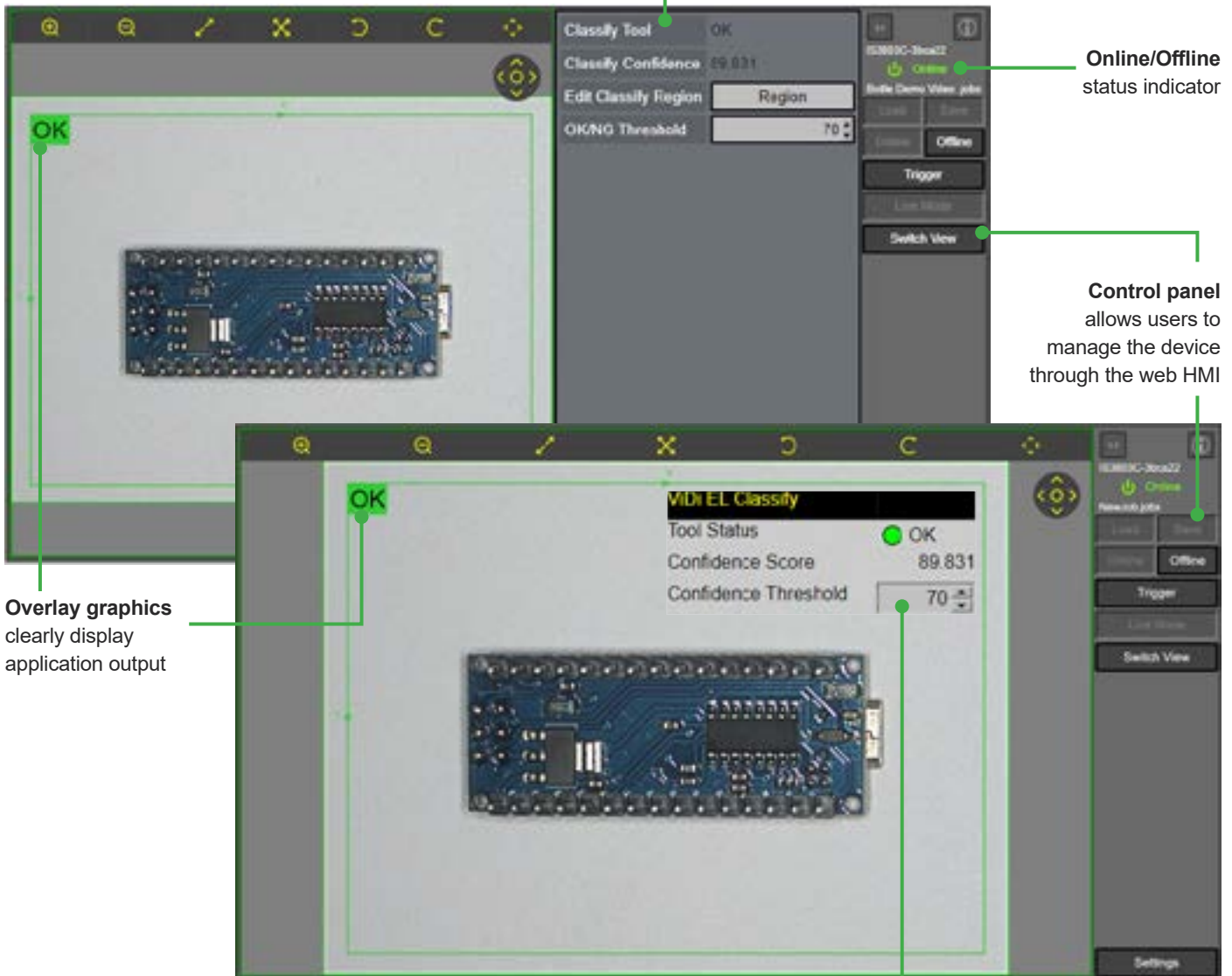

CustomView shows advanced settings from the spreadsheet



# Innovative technology pushes the boundaries of HDR

HDR+ enhances the capabilities of HDR technology by optimizing contrast automatically. This creates a more uniform, more detailed image in a single acquisition. Available in both monochrome and color options, HDR+ delivers higher contrast and image quality that allow you to:

- See features that were not visible before
- Reduce light intensity
- Increase depth of field

## Part inspection and OCR



Without HDR: Embedded parts are unclear.

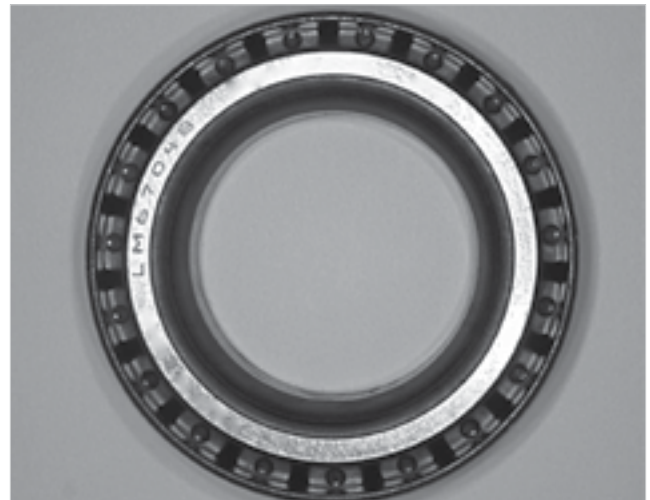

With HDR+: Serial code and bearings are both visible.

## Greater depth-of-field

HDR+ reduces over- and under-exposure, providing greater depth-of-field than standard HDR technology and conventional imaging sensors.

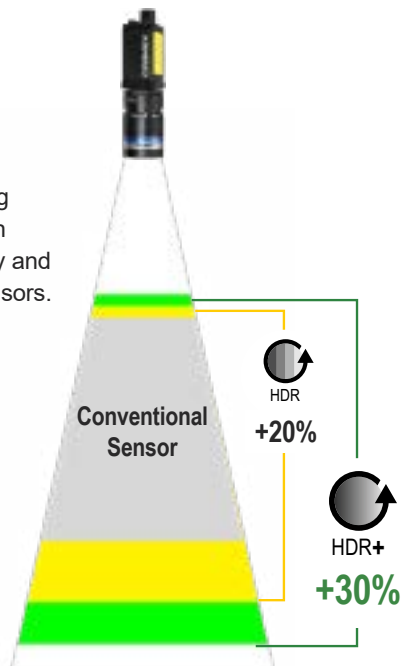

## Faster line speeds

HDR+ significantly reduces exposure times, enabling you to accommodate lines up to 80% faster.

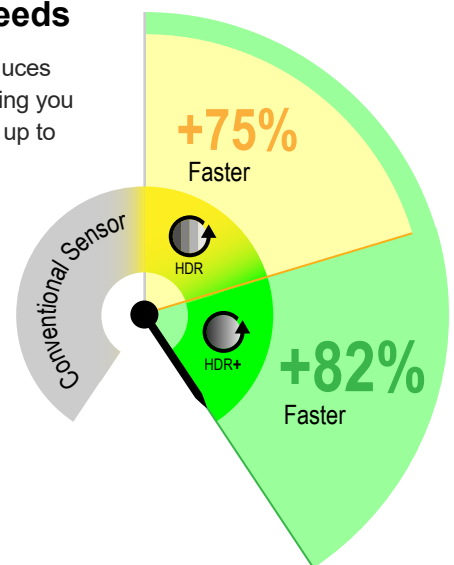

# Integrated design offers flexible performance

The In-Sight 8900 is engineered with the entire suite of innovative Cognex vision tools and convenient features that deliver fast, reliable automation.

Compatibility with C-mount lenses and High-Speed Liquid Lenses offers application flexibility and dynamic autofocus to optimize depth of field.



HDR+ mono and color options deliver high-quality, high-contrast images.

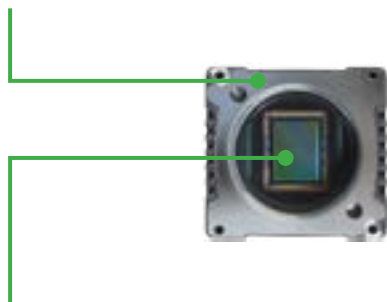

Multiple resolution options, including SVGA, 2MP, 5MP, and 12MP, support diverse needs.

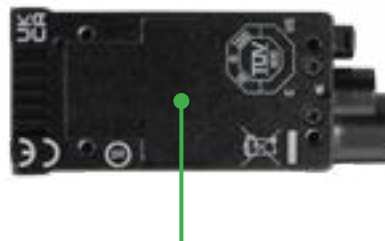

High-speed vision tool processing increases efficiency and throughput.

24V power and additional I/O



Class III PoE to simplify cable runs.

## In-Sight 8900 Series Specifications

Image Sensor	IS8900M	IS8900C	IS8902M	IS8902C	IS8905M	IS8905C	IS8912M	IS8912C
Bit Depth	8-bit monochrome	24-bit color	8-bit monochrome	24-bit color	8-bit monochrome	24-bit color	8-bit monochrome	24-bit color
Frames per Second (Maximum, Full Resolution)	142 fps	100 fps	86 fps	49 fps	47 fps	29 fps	21 fps	10 fps
Sensor Type	CMOS, global shutter		CMOS, global shutter		CMOS, global shutter		CMOS, global shutter	
Sensor Properties	2.7 mm diagonal, 2.74 x 2.74 $\mu\text{m}$ square pixels		6.2 mm diagonal, 2.74 x 2.74 $\mu\text{m}$ square pixels		8.8 mm diagonal, 2.74 x 2.74 $\mu\text{m}$ square pixels		14 mm diagonal, 2.74 x 2.74 $\mu\text{m}$ square pixels	
Maximum Image Resolution (pixels)	800 x 600		1920 x 1200		2448 x 2048		4096 x 3000	
Electronic Shutter Speed	29.1 us to 200,000 us		29.1 us to 200,000 us		29.1 us to 200,000 us		29.1 us to 200,000 us	

### Vision System

Memory	4 GB
Lens Type	C-Mount or Cognex High Speed Liquid Lens Autofocus
Discrete Inputs	1 opto-isolated, general purpose input
Discrete Outputs	Two opto-isolated, high speed outputs
Status LEDs	Network LED and two configurable LEDs
High Speed Liquid Lens Lifespan	Number of focus cycles: 1800 M cycles
Job/Program Memory	7.5 GB
Image Processing Memory	512 MB SDRAM
Network Communication	1 Ethernet port, 10/100/1000 BaseT with auto MDIX. IEEE 802.3 TCP/IP Protocol Supports DHCP, static, and link-local address configuration
Communication Protocols	TCP/IP, PROFINET, EtherNet/IP, SLMP, ModbusTCP, (S)FTP, RS-232C
Power Consumption	24 V DC $\pm$ 10%, 2.0 A maximum Class III Power over Ethernet (PoE) USB-C power 1.5 A minimum
Material	Die-cast aluminum and zinc housing
Finish	Painted
Mounting	Four M3 threaded mounting holes. See Accessories for supported mounts. Pattern: 44.25 mm (1.74 in) length, 22 mm (0.87 in) width side 1, 18 mm (0.71 in) width side 2
Weight	In-Sight 8900 with no accessories attached: 205 g (7.2 oz) With High Speed Liquid Lens (25 mm): 320 g (11.3 oz)
Ambient/Environment Temperature	0° C to 40° C (32° F to 104° F)
Storage Temperature	-20° C to 80° C (-4° F to 176° F)
Humidity	<95% non-condensing
Protection	IP40 with all cables properly attached and lens properly attached
Shock (Packaging)	IEC 60068-2-27: 18 shocks (3 shocks in each polarity in each (X, Y, Z) axis) 80 Gs (800 m/s <sup>2</sup> at 11 ms, half-sinusoidal) with cables or cable plugs and a 150 gram or lighter lens attached
Vibration (Shipping and Storage)	IEC 60068-2-6: vibration test in each of the three main axis for 2 hours at 10 Gs (10 to 500 Hz at 100 m/s <sup>2</sup> / 15 mm) with cables or cable plugs and a 150 gram or lighter lens attached
Regulations/Conformity	CE, FCC, KCC, TÜV SÜD NRTL, EU RoHS, China RoHS

# Field of view diagrams

**Working distances**  
Units: mm (*in*)

**Minimum**  
150 (5.9)

**Midpoint**  
500 (19.7)

**Maximum**  
1000 (39.4)

**SVGA with  
16 mm lens**

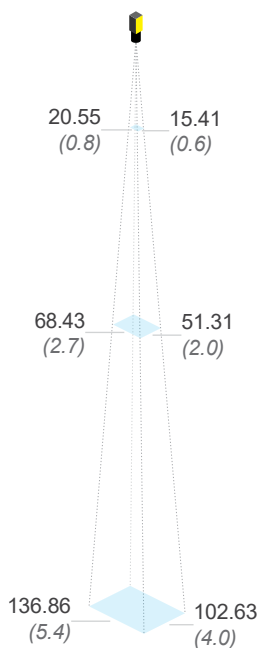

**2 MP with  
16 mm lens**

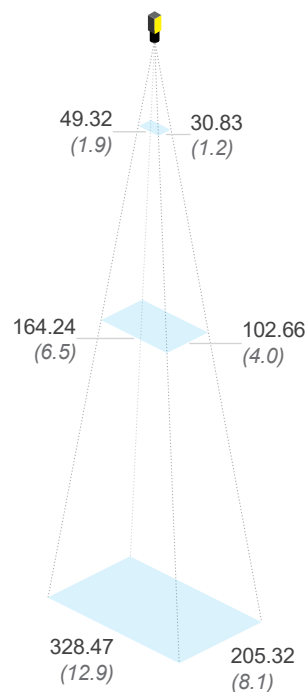

**Working distances**  
Units: mm (*in*)

**Minimum**  
150 (5.9)

**Midpoint**  
500 (19.7)

**Maximum**  
1000 (39.4)

**5 MP with  
16 mm lens**

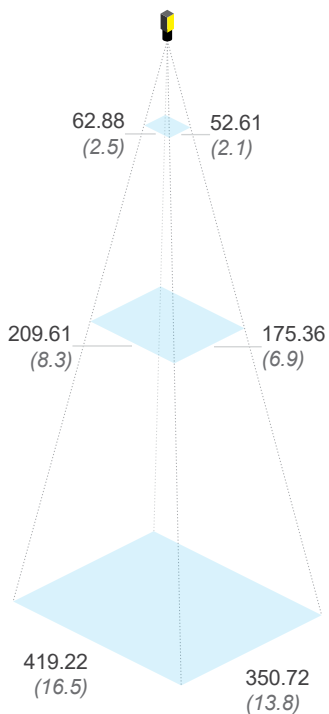

**12 MP with  
16 mm lens**

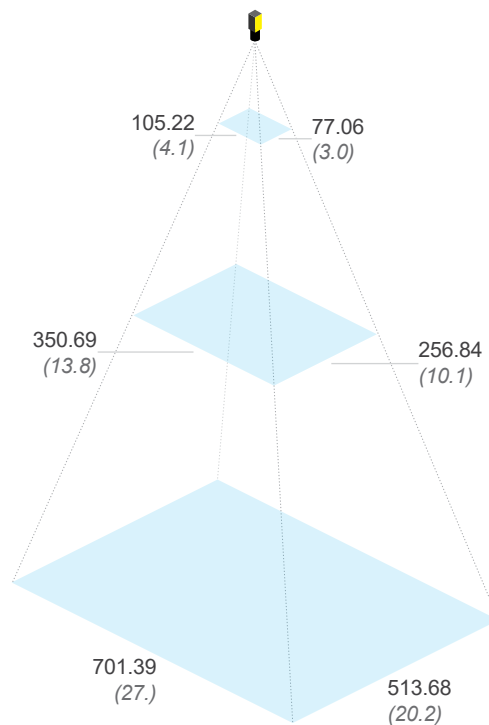

Field of view diagrams are based on the minimum and maximum focus distances of the High Speed Liquid Lens.

# Field of view diagrams

Working distances  
Units: mm (in)

**SVGA with  
25 mm lens**

**2 MP with  
25 mm lens**

**5 MP with  
25 mm lens**

**Minimum**  
300 (11.8)

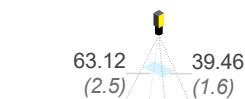
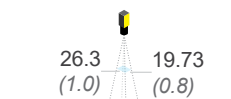

**Midpoint**  
1000 (39.4)



**Maximum**  
4000 (157.5)

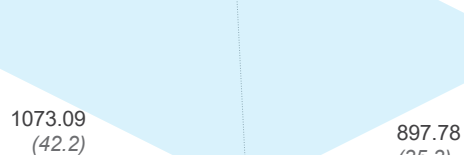
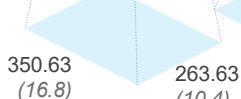

Working distances  
Units: mm (in)

**12 MP with  
25 mm lens**

**Minimum**  
300 (11.8)

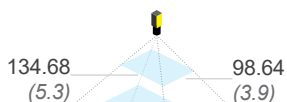

**Midpoint**  
1000 (39.4)



**Maximum**  
4000 (157.5)



Field of view diagrams are based on the minimum and maximum focus distances of the High Speed Liquid Lens.

# Field of view diagrams

Working distances  
Units: mm (in)

**Minimum**  
500 (19.7)

**Midpoint**  
1000 (39.4)

**Maximum**  
4000 (157.5)

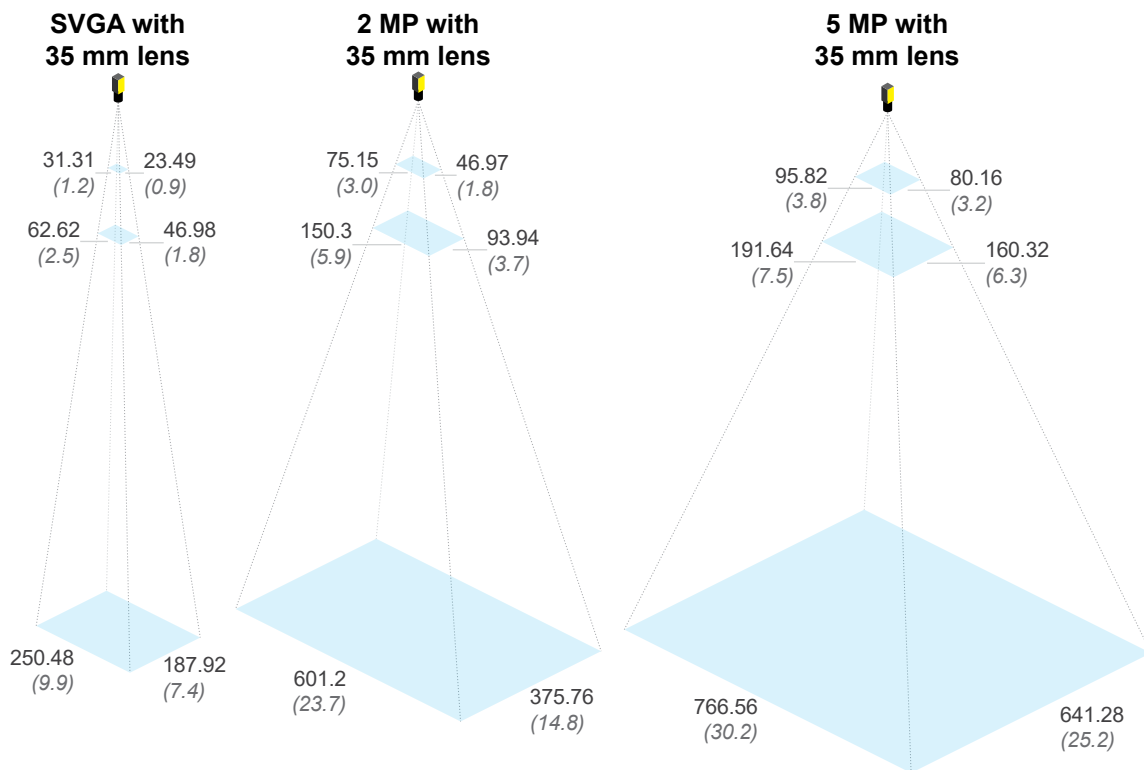

Working distances  
Units: mm (in)

**Minimum**  
500 (19.7)



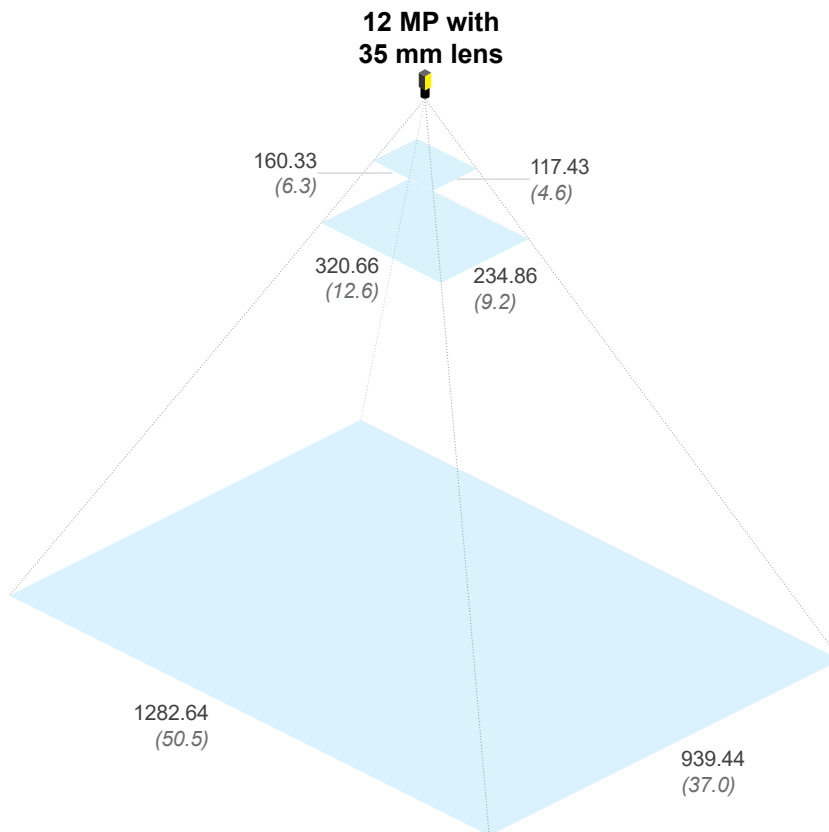

**Midpoint**  
1000 (39.4)

**Maximum**  
4000 (157.5)





Field of view diagrams are based on the minimum and maximum focus distances of the High Speed Liquid Lens.



## In-Sight 8900 Series



	Product ID	Resolution	Mono/Color	Performance	Lens Connector	Toolset
	IS8900MX-01-SA	SVGA	Mono	Max	C-mount only	EB/SS, all tools
	IS8900CX-01-SA	SVGA	Color	Max	C-mount only	EB/SS, all tools
	IS8900MX-01-SR	SVGA	Mono	Max	C-mount only	EB/SS, Rule-Based
	IS8900CX-01-SR	SVGA	Color	Max	C-mount only	EB/SS, Rule-Based
	IS8900MX-02-SA	SVGA	Mono	Max	HSSL adapter	EB/SS, all tools
	IS8900CX-02-SA	SVGA	Color	Max	HSSL adapter	EB/SS, all tools
	IS8900MX-02-SR	SVGA	Mono	Max	HSSL adapter	EB/SS, Rule-Based
	IS8900CX-02-SR	SVGA	Color	Max	HSSL adapter	EB/SS, Rule-Based
	IS8902MX-01-SA	2 MP	Mono	Max	C-mount only	EB/SS, all tools
	IS8902CX-01-SA	2 MP	Color	Max	C-mount only	EB/SS, all tools
	IS8902MX-01-SR	2 MP	Mono	Max	C-mount only	EB/SS, Rule-Based
	IS8902CX-01-SR	2 MP	Color	Max	C-mount only	EB/SS, Rule-Based
	IS8902MX-02-SA	2 MP	Mono	Max	HSSL adapter	EB/SS, all tools
	IS8902CX-02-SA	2 MP	Color	Max	HSSL adapter	EB/SS, all tools
	IS8902MX-02-SR	2 MP	Mono	Max	HSSL adapter	EB/SS, Rule-Based
	IS8902CX-02-SR	2 MP	Color	Max	HSSL adapter	EB/SS, Rule-Based
	IS8905MX-01-SA	5 MP	Mono	Max	C-mount only	EB/SS, all tools
	IS8905CX-01-SA	5 MP	Color	Max	C-mount only	EB/SS, all tools
	IS8905MX-01-SR	5 MP	Mono	Max	C-mount only	EB/SS, Rule-Based
	IS8905CX-01-SR	5 MP	Color	Max	C-mount only	EB/SS, Rule-Based
	IS8905MX-02-SA	5 MP	Mono	Max	HSSL adapter	EB/SS, all tools
	IS8905CX-02-SA	5 MP	Color	Max	HSSL adapter	EB/SS, all tools
	IS8905MX-02-SR	5 MP	Mono	Max	HSSL adapter	EB/SS, Rule-Based
	IS8905CX-02-SR	5 MP	Color	Max	HSSL adapter	EB/SS, Rule-Based
	IS8912MX-01-SA	12 MP	Mono	Max	C-mount only	EB/SS, all tools
	IS8912CX-01-SA	12 MP	Color	Max	C-mount only	EB/SS, all tools
	IS8912MX-01-SR	12 MP	Mono	Max	C-mount only	EB/SS, Rule-Based
	IS8912CX-01-SR	12 MP	Color	Max	C-mount only	EB/SS, Rule-Based
	IS8912MX-02-SA	12 MP	Mono	Max	HSSL adapter	EB/SS, all tools
	IS8912CX-02-SA	12 MP	Color	Max	HSSL adapter	EB/SS, all tools
	IS8912MX-02-SR	12 MP	Mono	Max	HSSL adapter	EB/SS, Rule-Based
	IS8912CX-02-SR	12 MP	Color	Max	HSSL adapter	EB/SS, Rule-Based

# Components and accessories

Lenses		
	Product ID	Description
	ML-M0625UR <sup>1</sup>	6 mm Moritex UR series lens
	ML-M0822UR <sup>1</sup>	8 mm Moritex UR series lens
	ML-M1218UR <sup>1</sup>	12 mm Moritex UR series lens
	ML-M1616UR <sup>1</sup>	16 mm Moritex UR series lens
	ML-M2516UR <sup>1</sup>	25 mm Moritex UR series lens
	ML-M3520UR <sup>1</sup>	35 mm Moritex UR series lens
	ML-M5025UR <sup>1</sup>	50 mm Moritex UR series lens
	CLN-C16F65-HSLL-HR <sup>3</sup>	25 mm HSSL - high resolution
	CLN-C25F65-HSLL-HR <sup>3</sup>	35 mm HSSL - high resolution
	CLN-C35F06-HSLL-HR <sup>3</sup>	16 mm HSSL - high resolution
	ML-U0618SR-18C <sup>2</sup>	6 mm Moritex SR series lens
	ML-U1217SR-18C <sup>2</sup>	12 mm Moritex SR series lens
	ML-U1615SR-18C <sup>2</sup>	16 mm Moritex SR series lens
	ML-U2515SR-18C <sup>2</sup>	25 mm Moritex SR series lens
	ML-U3518SR-18C <sup>2</sup>	35 mm Moritex SR series lens
	ML-U5022SR-18C <sup>2</sup>	50 mm Moritex SR series lens

- 1 Compatible with 8900/8902/8905.
- 2 Compatible with 8912.
- 3 Compatible with ALL.

Mounting Brackets		
	Product ID	Description
	BKT-IS8K-01 <sup>3</sup>	Mounting Bracket, Provides 1/4-20 Mounting Holes
	BKT-IS8K-02 <sup>3</sup>	Thermal cooling bracket, Provides 1/4-20 Mounting Holes

Cables		
	Product ID	Description
	CCB-84901-2001-XX <sup>3</sup>	Ethernet cable, X-coded M12-8 to RJ-45 (2 m, 5 m, 10 m, 15 m, 30 m)
	CCB-84901-2RBT-XX <sup>3</sup>	Ethernet cable, X-coded M12-8 to RJ-45 (2 m, 5 m, 10 m)
	CCB-PWRIOM8-S-XX <sup>3</sup>	Breakout cable, M8-8 to flying lead (5 m, 10 m, 15 m)
	CCB-M8CONVTR <sup>3</sup>	M8-5 to M8-8 converter cable

VisionView		
	Product ID	Description
	VVW-P <sup>3</sup>	VV Web HDMI Panel
	VVW-H-AU <sup>3</sup>	CFKIT, VV Web HDMI with AU PS
	VVW-H-EU <sup>3</sup>	CFKIT, VV Web HDMI with EU PS
	VVW-H-NOM <sup>3</sup>	CFKIT, VV Web HDMI with NOM PS
	VVW-H-UK <sup>3</sup>	CFKIT, VV Web HDMI with UK PS
	VVW-H-US <sup>3</sup>	CFKIT, VV Web HDMI with US PS



# Dimensions Units: mm, [in]

## In-Sight 8900 Base Unit

[Download CAD files](#)

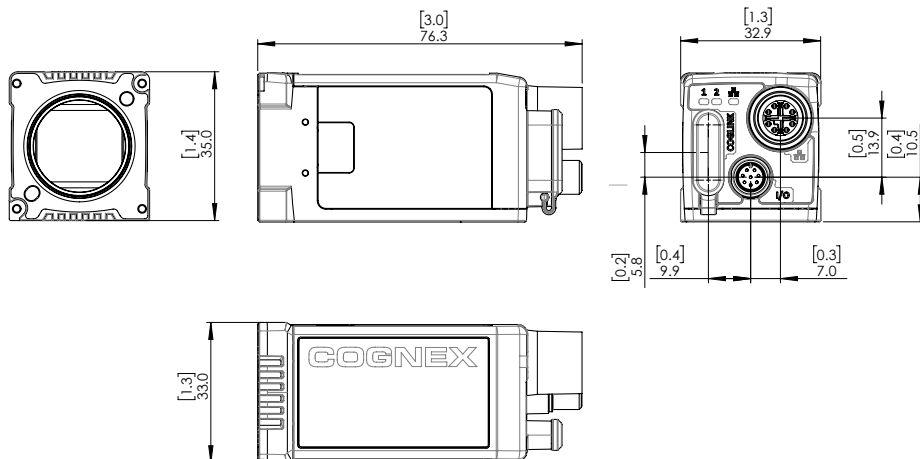

## In-Sight 8900 with Autofocus Lens

[Download CAD files](#)

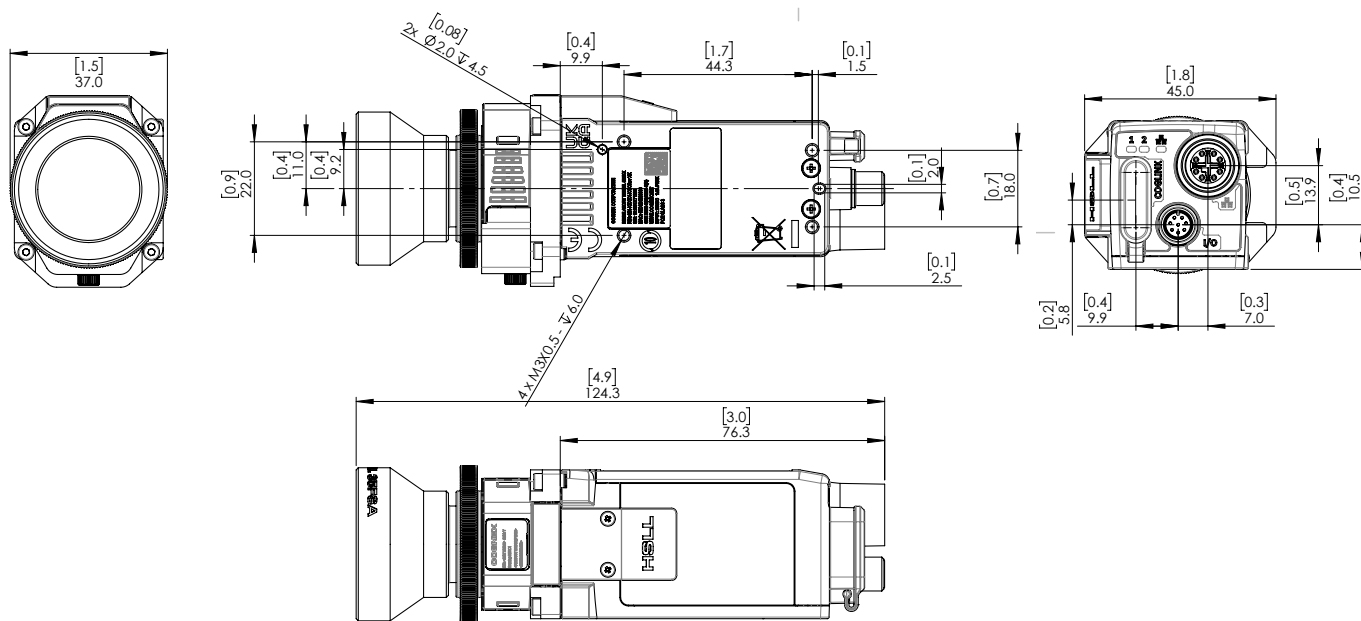

# Build Your Vision

## Vision Systems

Advanced AI makes it easy to deploy vision systems for automating inspection tasks, from defect detection to assembly verification and text reading.

[www.cognex.com/machine-vision](http://www.cognex.com/machine-vision)



## Barcode Readers

Track and trace from the floor to dock door, with flexible readers and verifiers designed for ease of use and reliability.

[www.cognex.com/barcodereaders](http://www.cognex.com/barcodereaders)



## Industry Solutions

Tackle complex applications across a wide range of industries with powerful machine vision solutions that simplify today's manufacturing and logistics challenges.

[www.cognex.com/solutions](http://www.cognex.com/solutions)



# COGNEX

Companies around the world rely on Cognex vision and barcode reading solutions to optimize quality, drive down costs, and control traceability.

### Corporate Headquarters One Vision Drive Natick, MA 01760 USA

Contact us or find your regional sales office:  
[www.cognex.com/sales](http://www.cognex.com/sales)

#### Americas

North America +1 855 426 4639  
Brazil +1 855 426 4639  
Mexico +52 552 789 5444

#### Europe

Austria +49 721 958 8052  
Belgium (FR) +33 176 549 318  
France +33 176 549 318  
Germany +49 721 958 8052  
Ireland +353 21 601 9005  
Italy +39 02 9475 4345  
Spain +34 93 220 6237  
Switzerland (DE) +49 721 958 8052  
Switzerland (FR) +33 176 549 318  
United Kingdom +353 21 601 9005  
Other Europe +353 21 601 9005

#### Asia-Pacific

China +86 218 036 5424  
India +91 7305 040397  
Japan +81 345 790 266  
Korea +82 704 784 4038  
Singapore +65 3158 2511  
Taiwan +886 801 492 017  
Other Asia-Pacific +65 3158 2511

© Copyright 2025, Cognex Corporation.  
All information in this document is subject to change without notice. All Rights Reserved.  
Cognex and In-Sight are registered trademarks of Cognex Corporation. All other trademarks are property of their respective owners.

Lit. No. IS8900DS-EN-02-2025

[www.cognex.com](http://www.cognex.com)